

**MERCEDES BENZ C-KLASSE W 204**  
**MERCEDES BENZ C-KLASSE S 204**  
**MERCEDES BENZ GLK-KLASSE X 204**  
**MERCEDES BENZ C204 Coupé**

**03/07 >> 02/14**  
**12/07 >> 08/14**  
**06/08 >>**  
**04/11 >>**

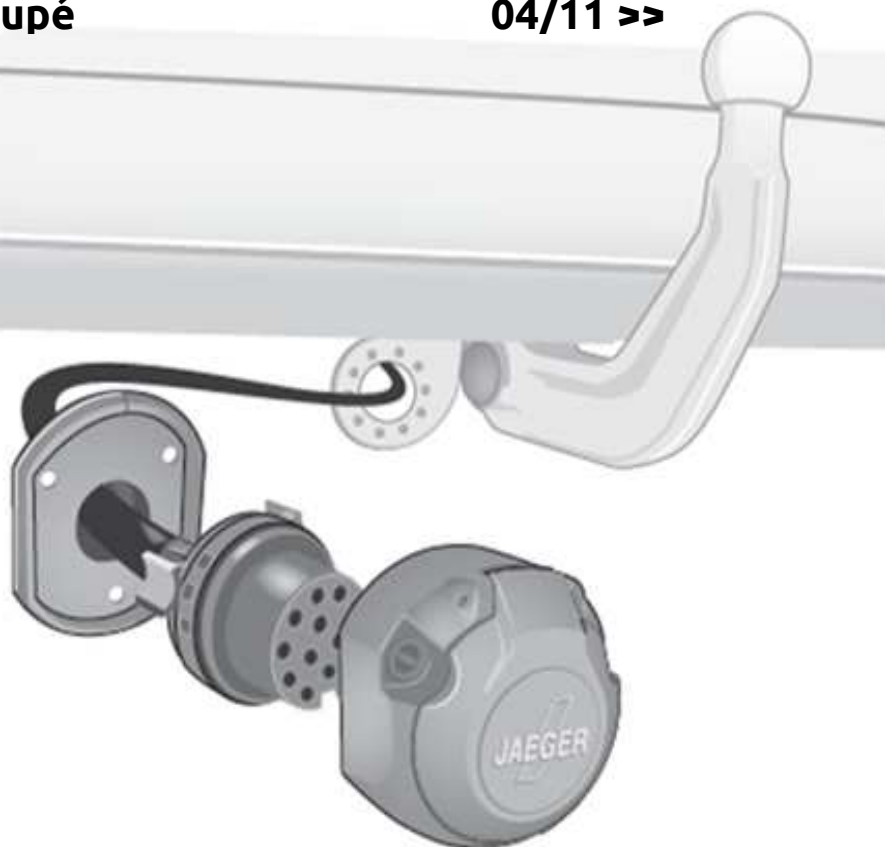

- D** Einbauanleitung  
Elektro-Einbausatz für Anhängerkupplung / 13-polig / 12 Volt / ISO 11446
- GB** Fitting instructions  
Electric wiring kit for towbars / 13-pin / 12 Volt / ISO 11446
- F** Instructions de montage  
Faisceau pour attelage / 13 broches / 12 Volt / ISO 11446
- I** Istruzione di montaggio  
Cablaggio elettrico per ganci di traino / 13 poli / 12 Volt / ISO 11446
- E** Instrucciones de montaje  
Kits eléctricos para enganches de remolques / 13 pins / 12 Volt / ISO 11446
- NL** Montagehandleiding  
Elektro-inbouwset voor aanhangerkoppeling / 13-polig / 12 Volt / ISO 11446

# KIT

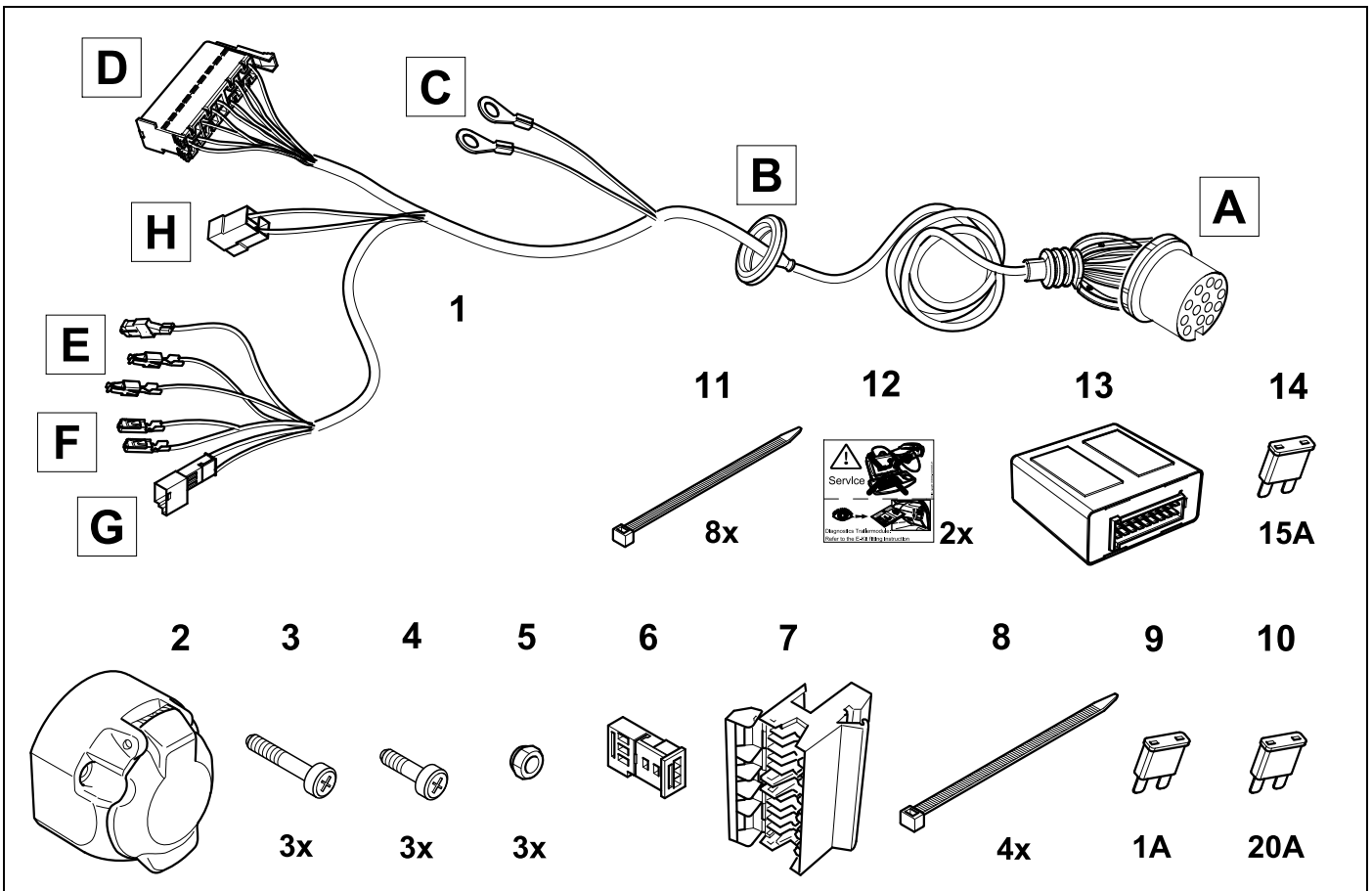

# TOOLS

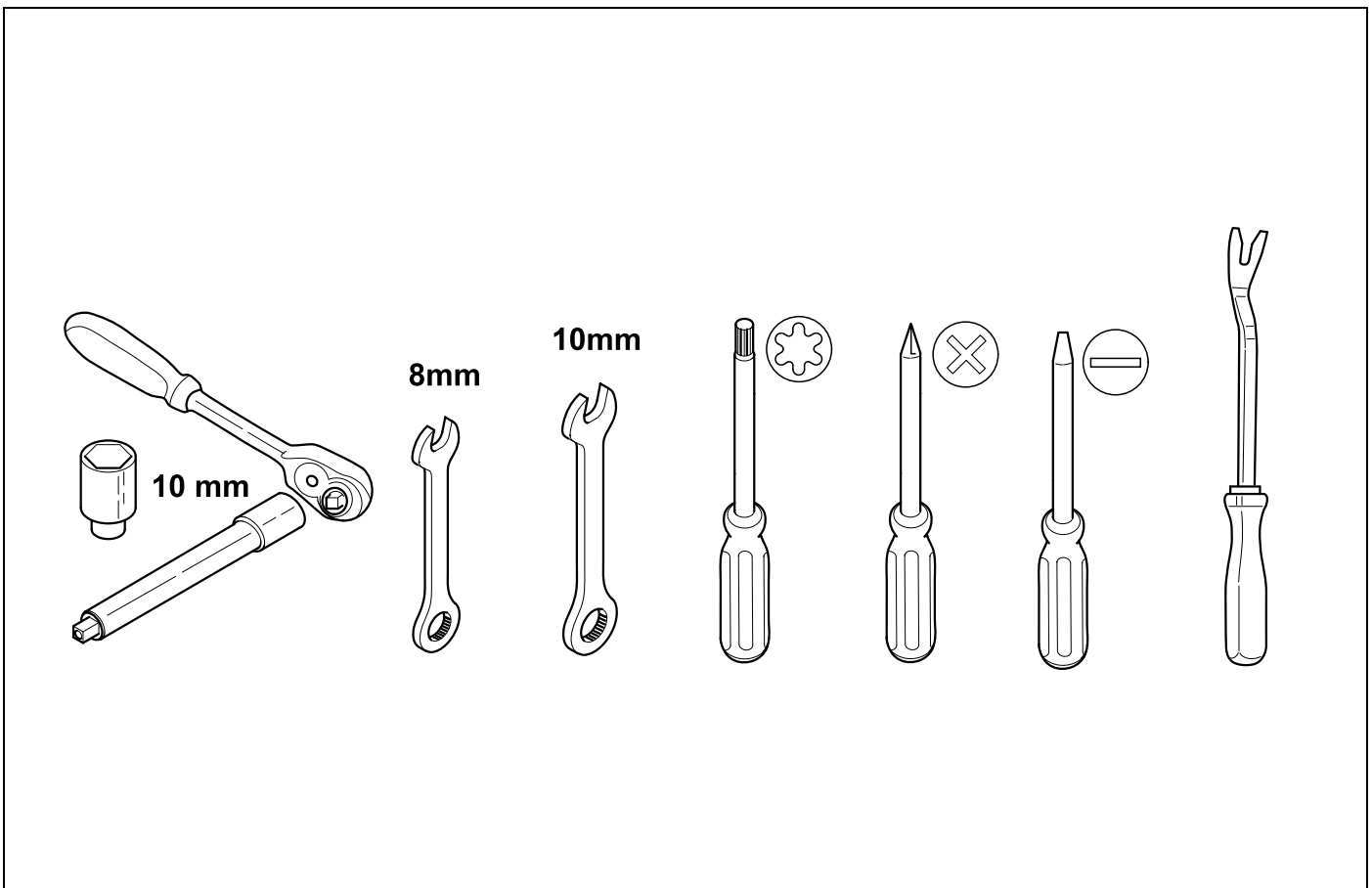



[www.jaeger-automotive.de](http://www.jaeger-automotive.de)



**HOTLINE** +49 5246 921019  
[support@jaeger-automotive.de](mailto:support@jaeger-automotive.de)

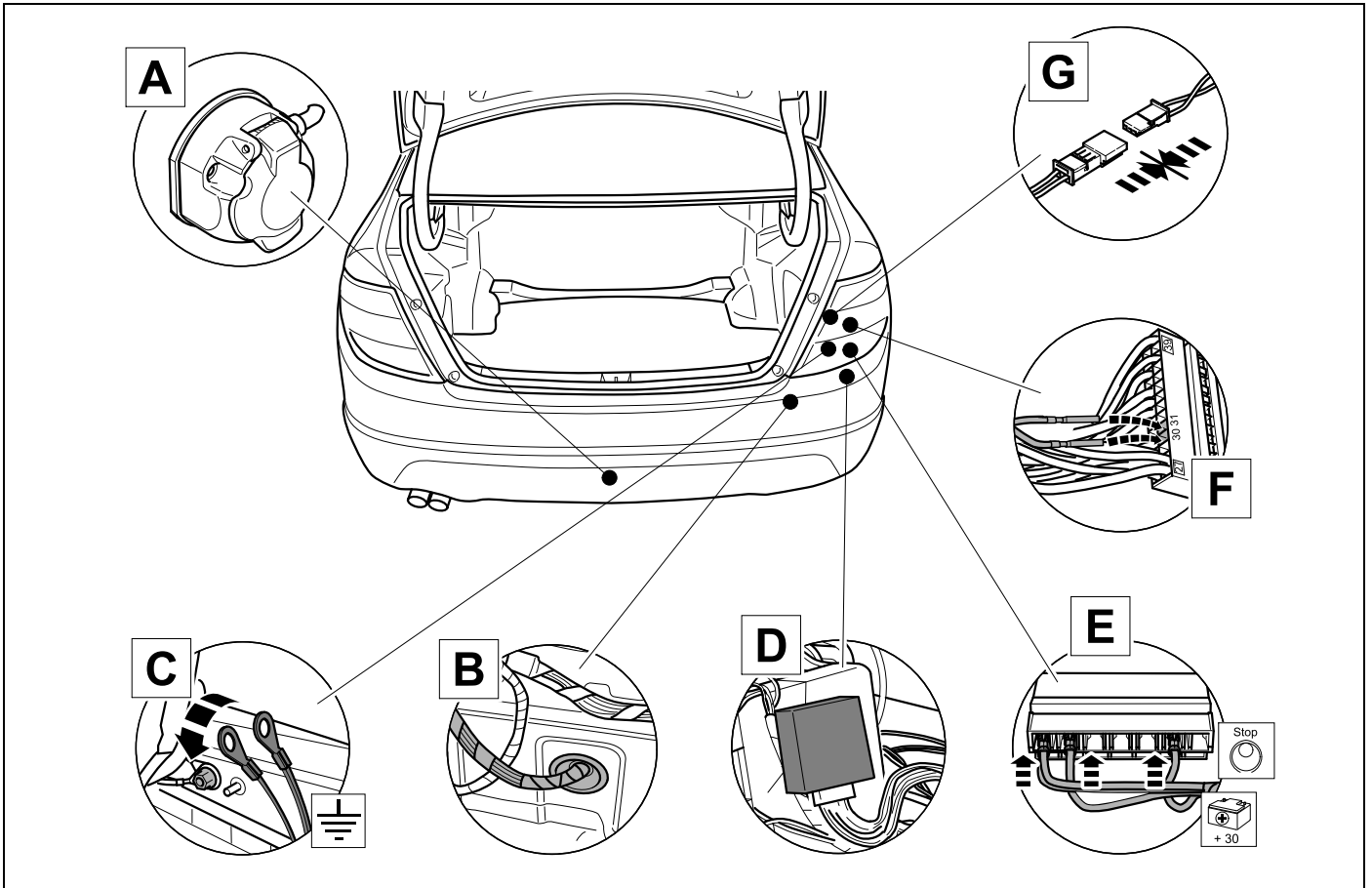

# S 204

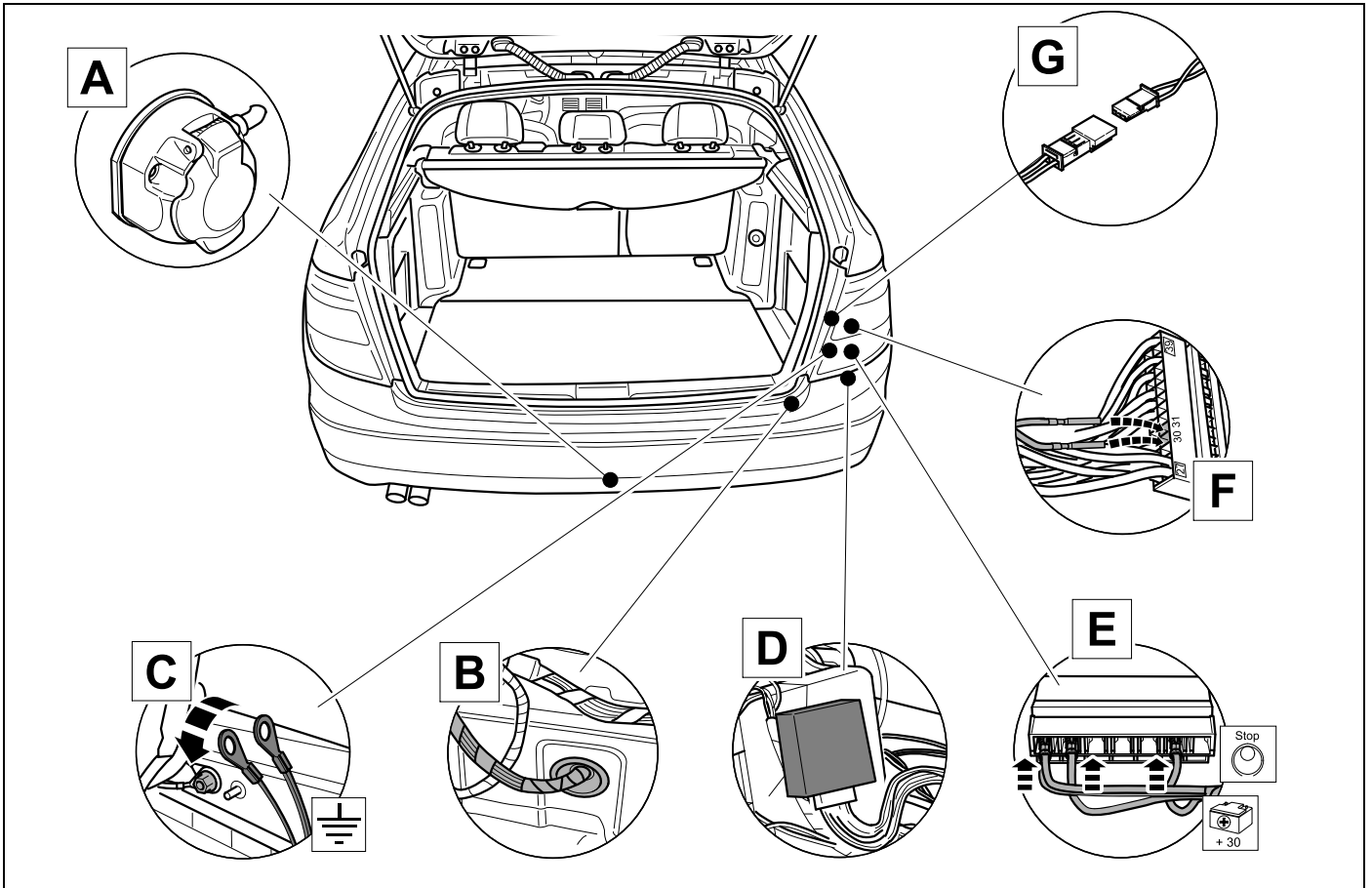

# X 204

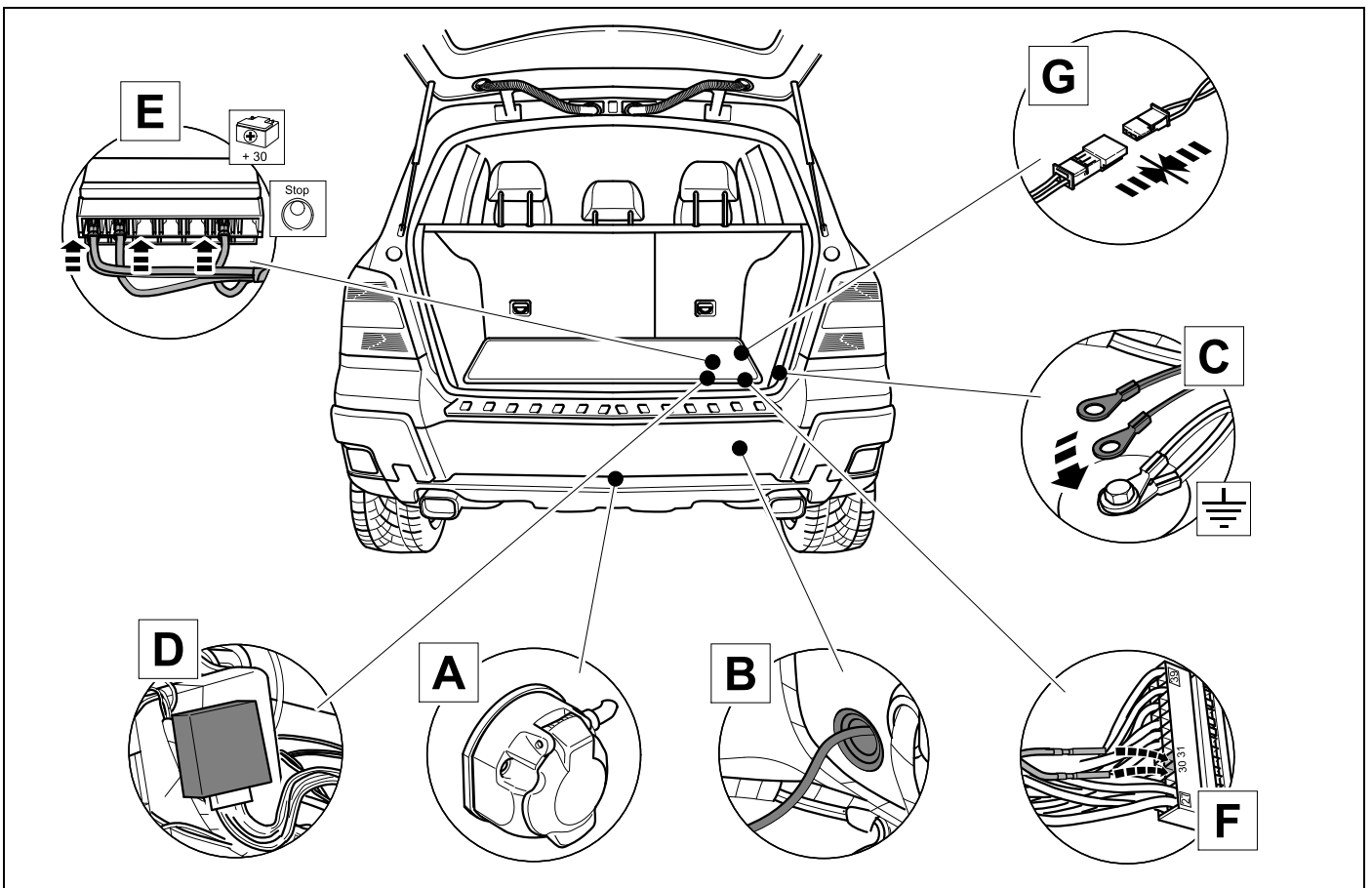

1

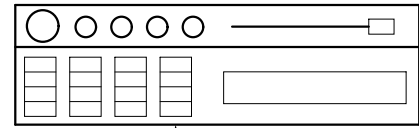
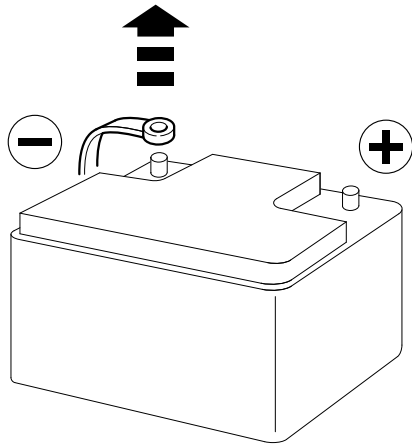

Radio Code

2

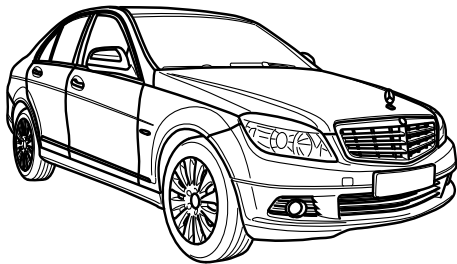

W/C 204

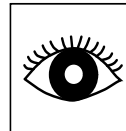
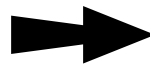

3

5

-

9



20



S 204

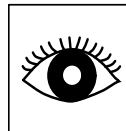

4

-

9



20

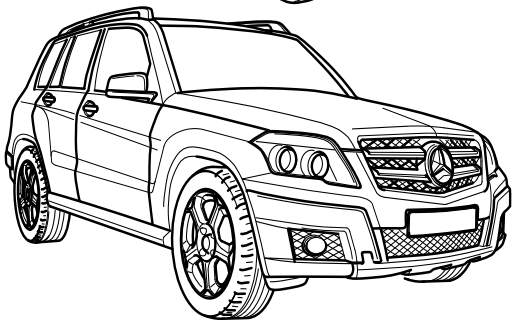

X 204

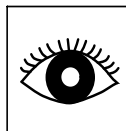

10

-

20

# 3 REMOVE

W/C 204

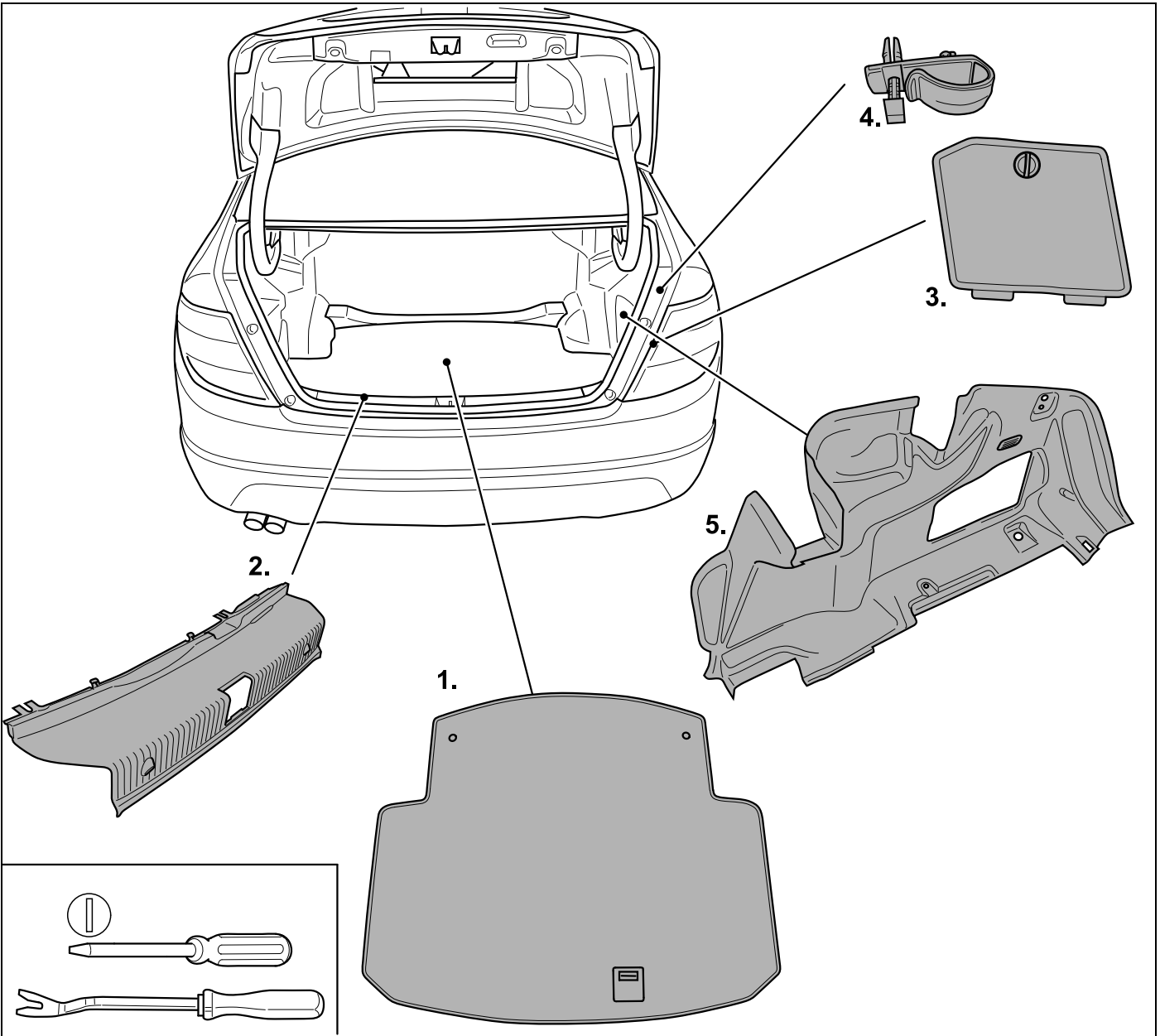

# 4 REMOVE

S 204

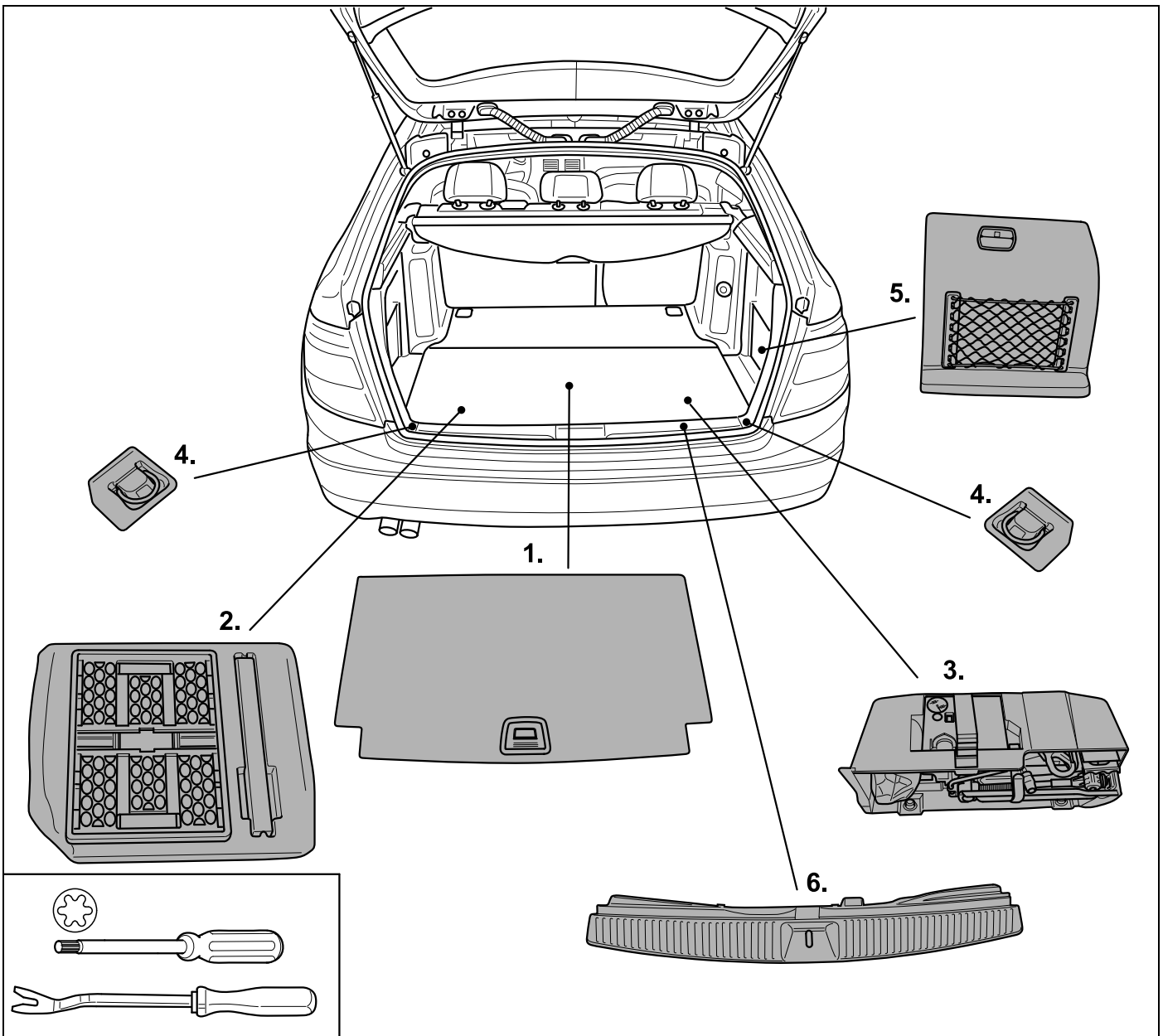

# 5

W/C 204 / S 204

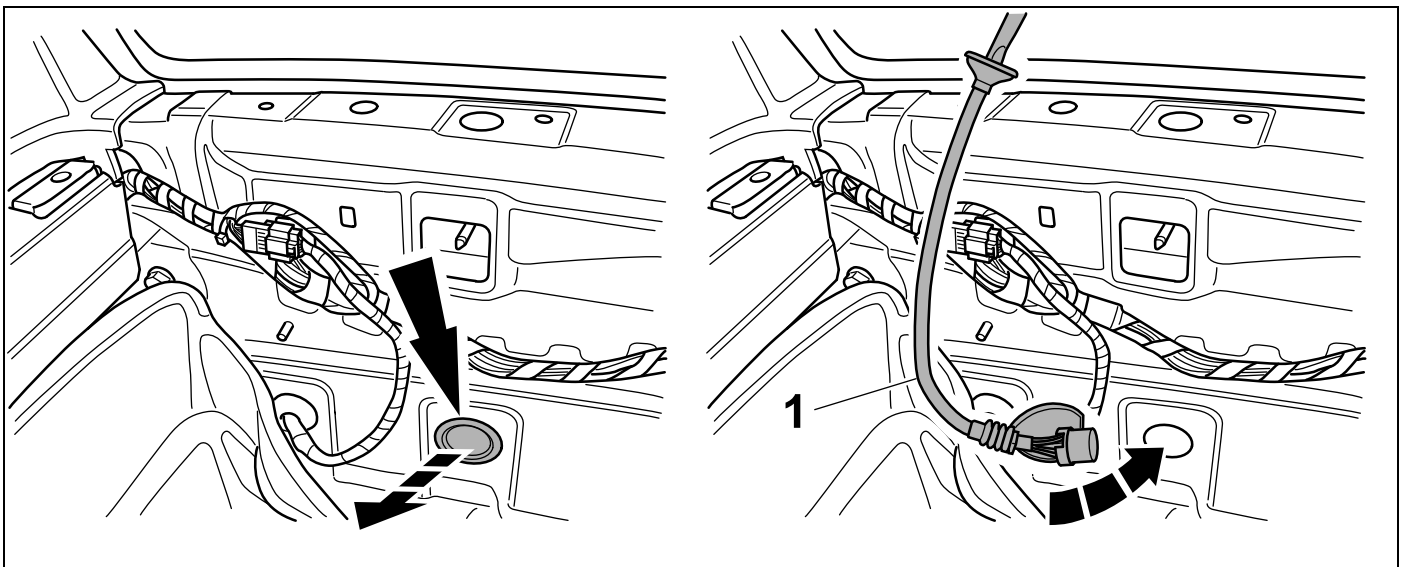



6

W/C 204 / S 204

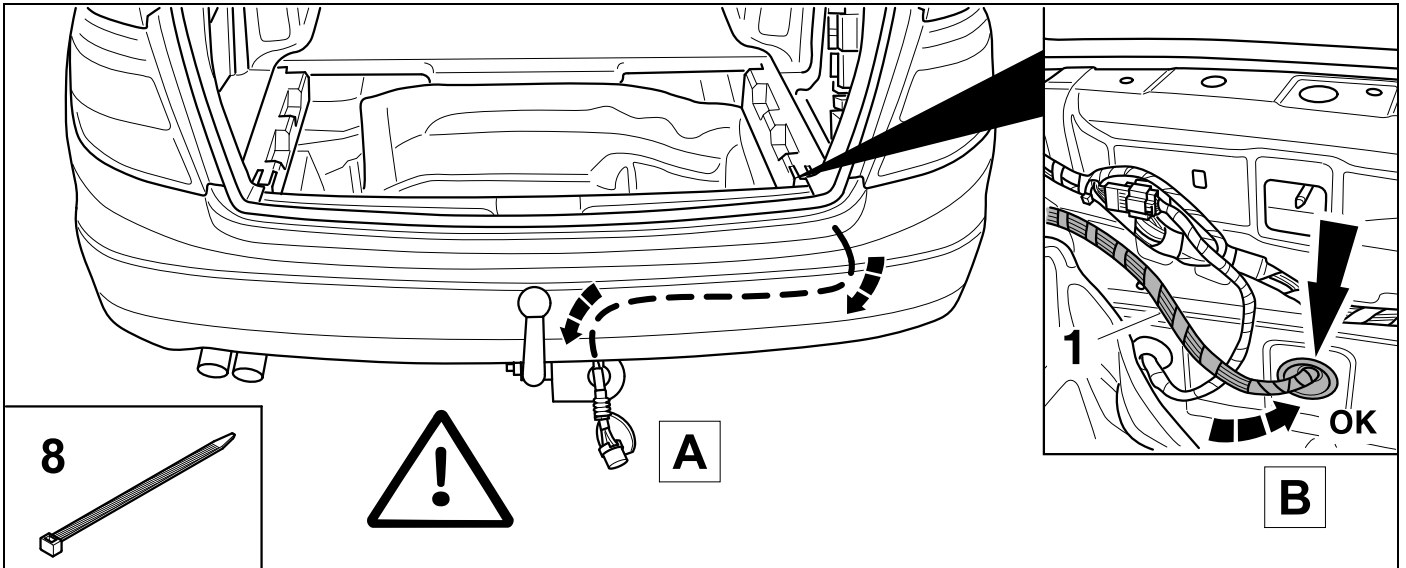

8

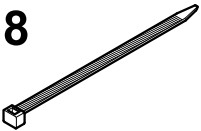

A

B

7

W/C 204 / S 204

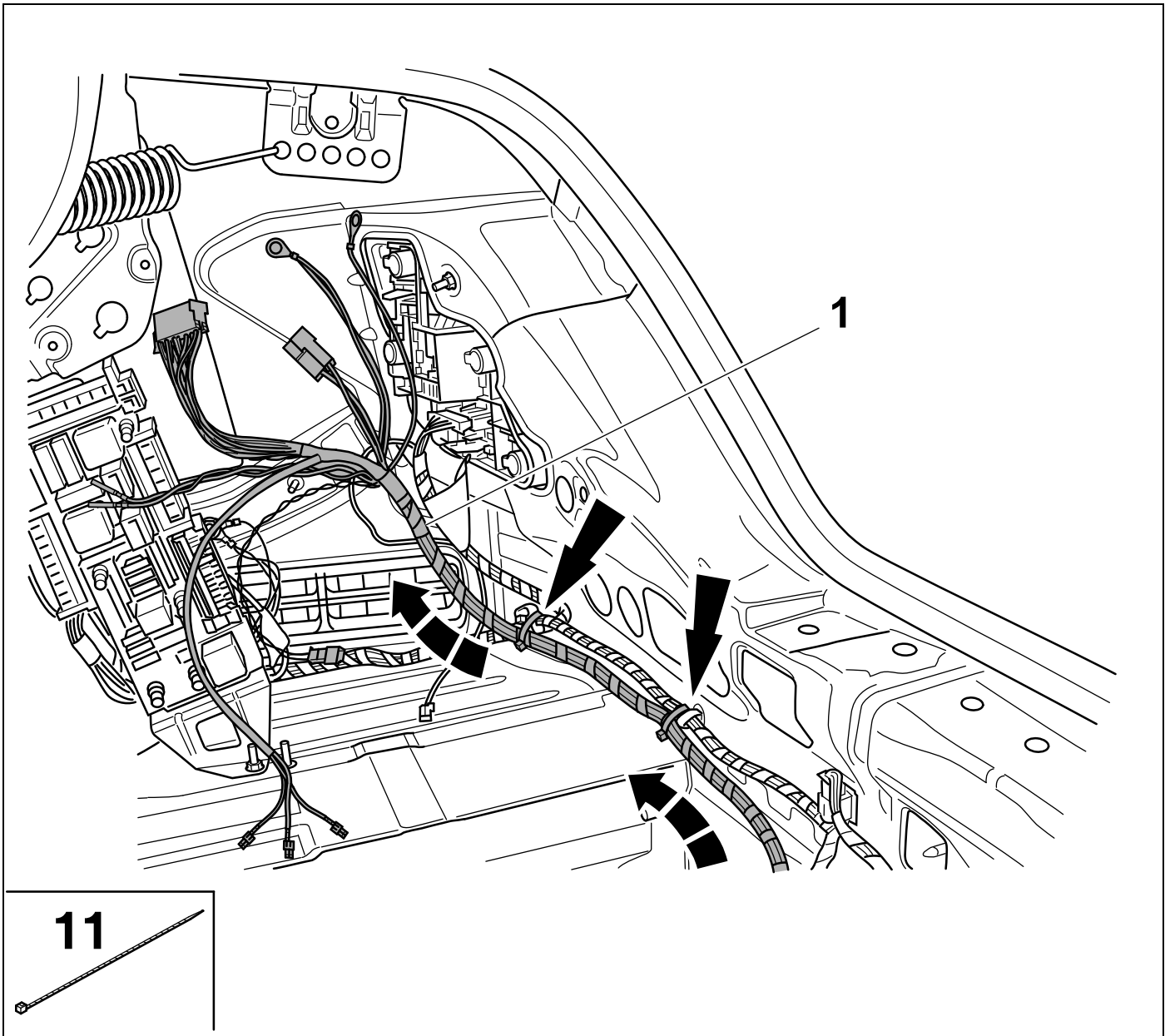

11

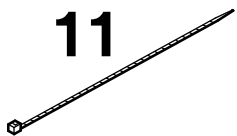

8

W/C 204 / S 204

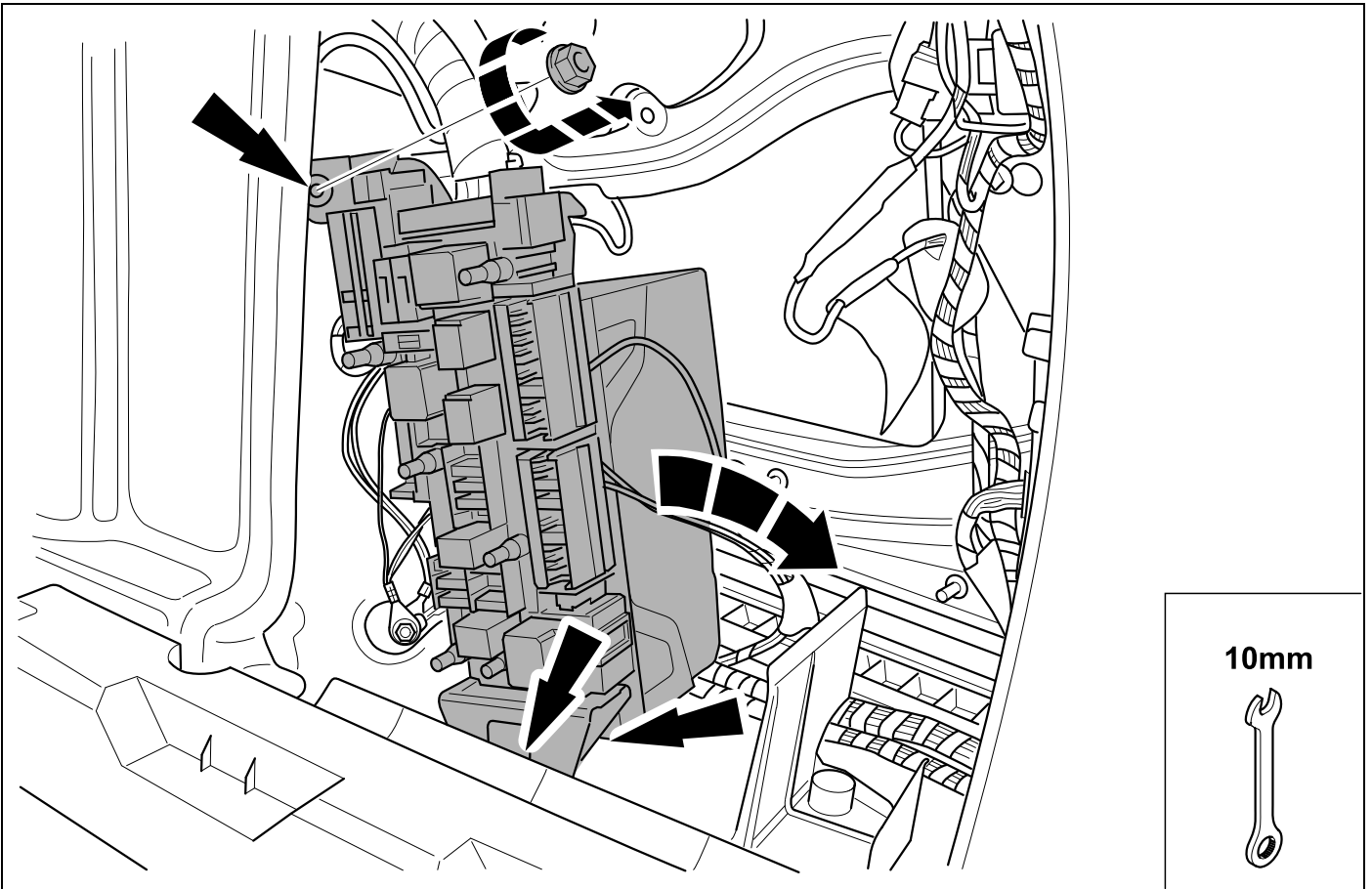

9

W/C 204 / S 204

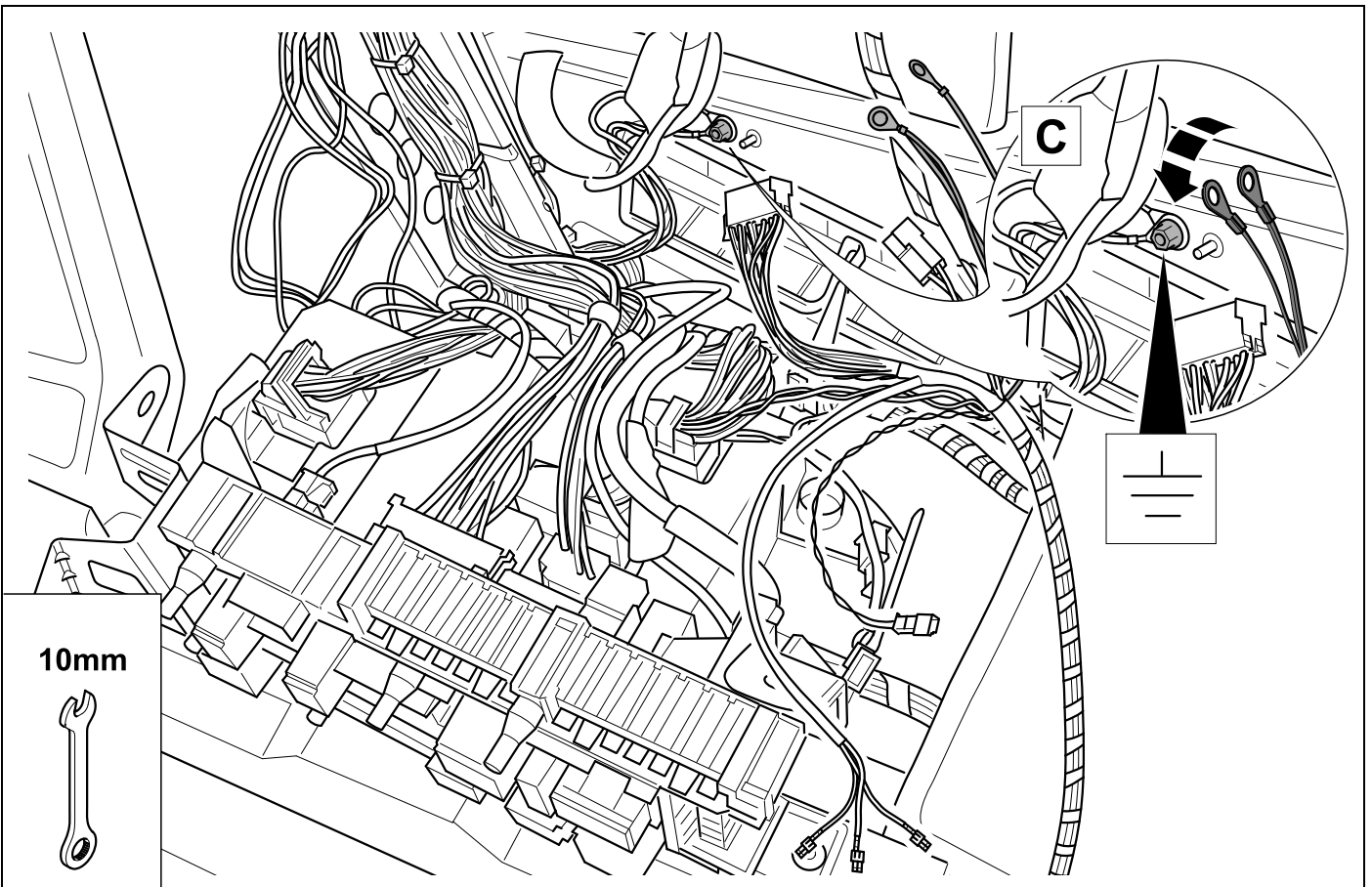

# 10 REMOVE

X 204

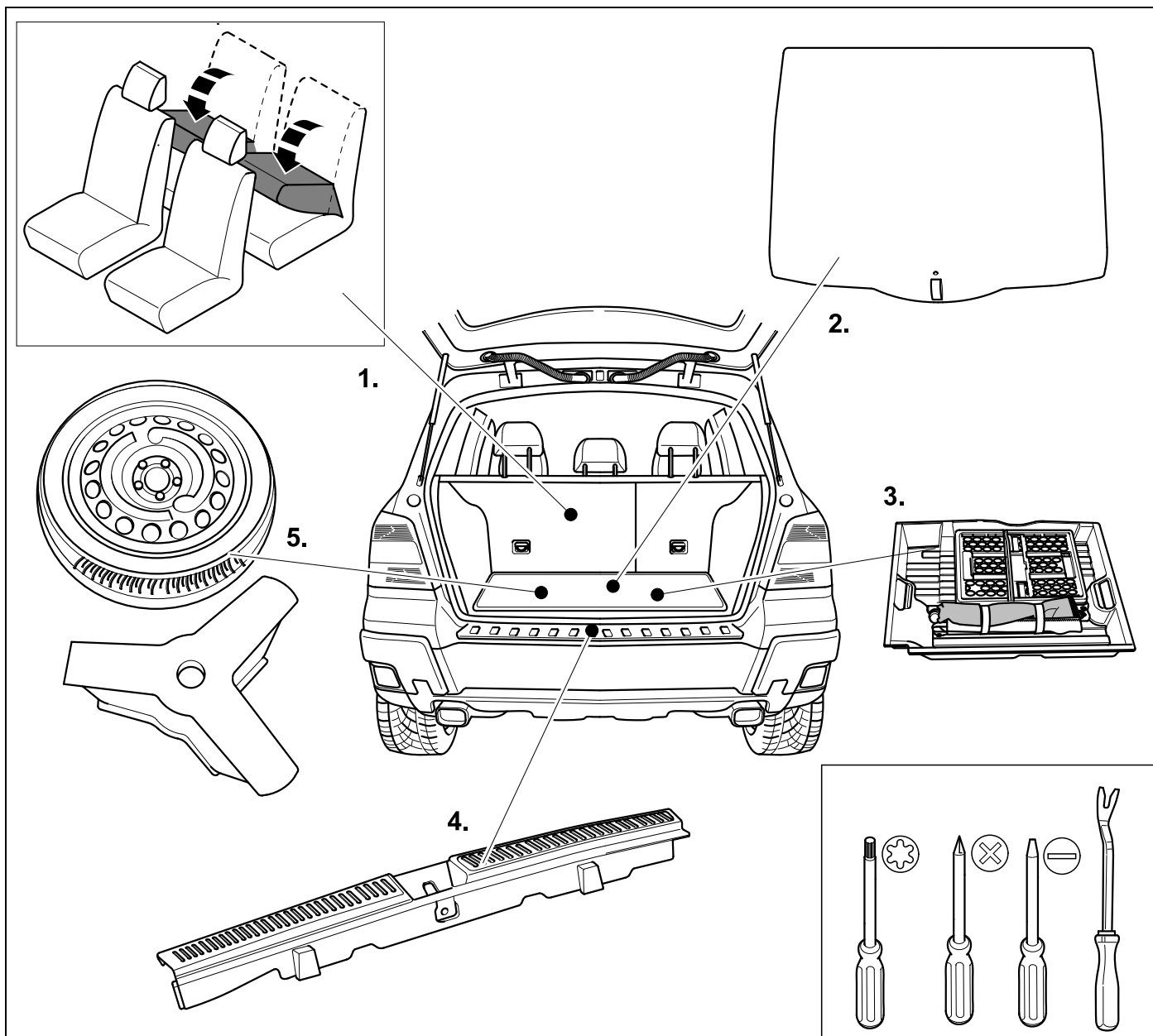

# 11 REMOVE

X 204

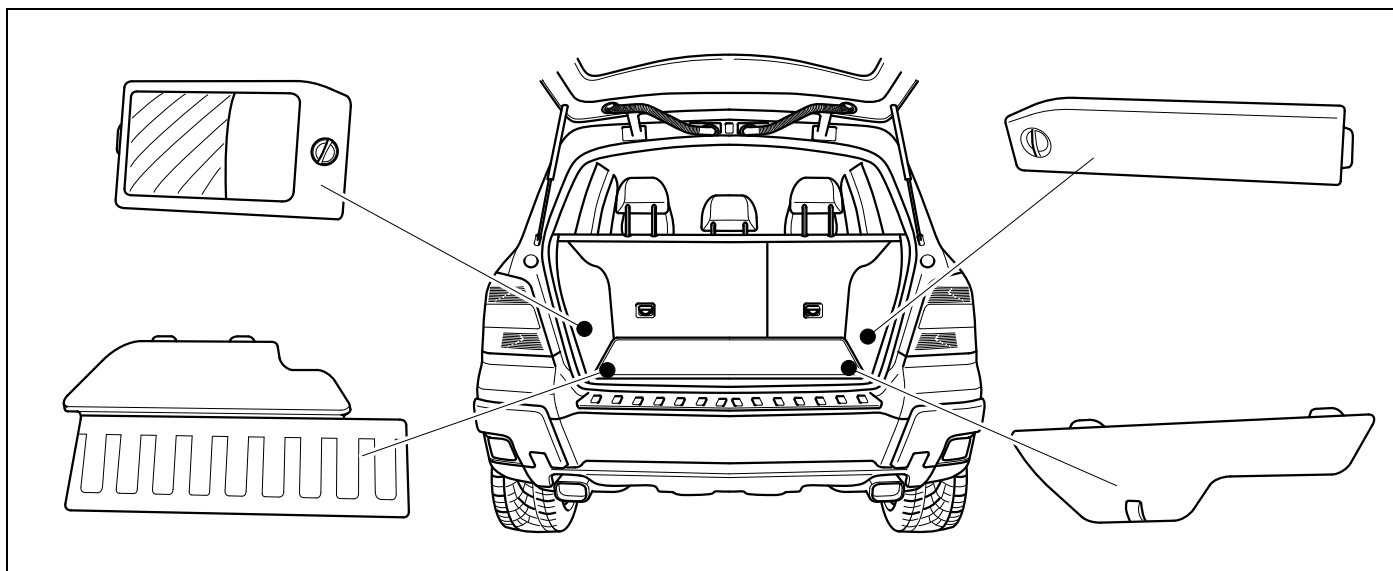

# 12 REMOVE

X 204

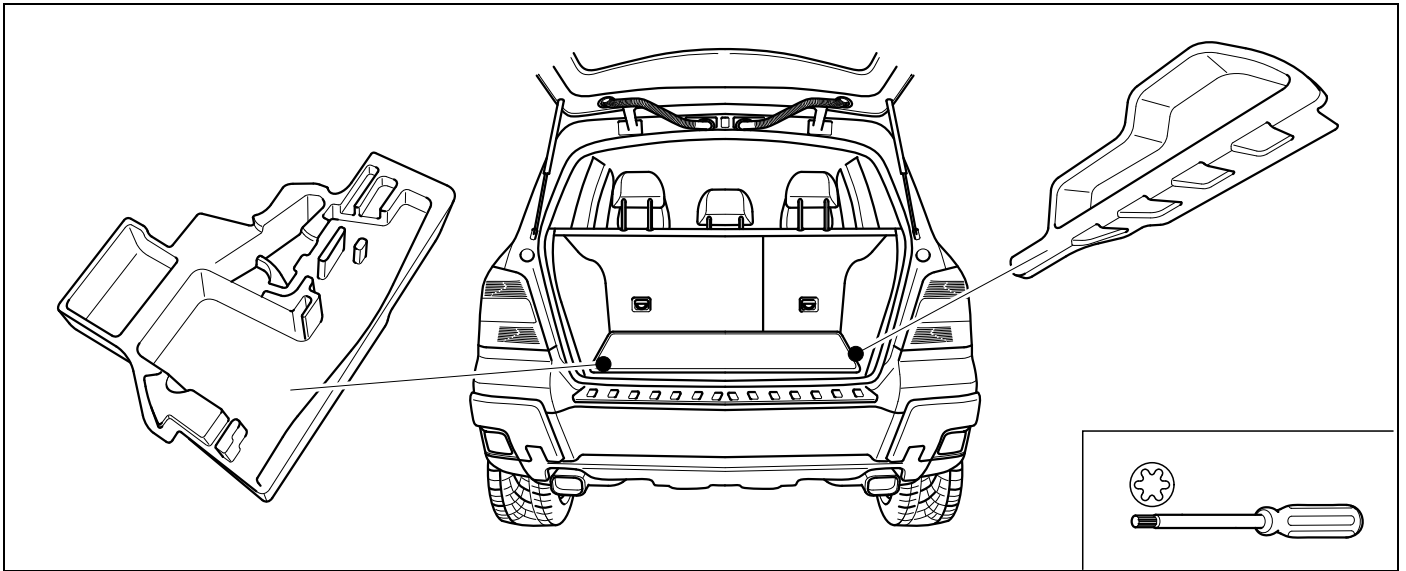

# 13 REMOVE

X 204

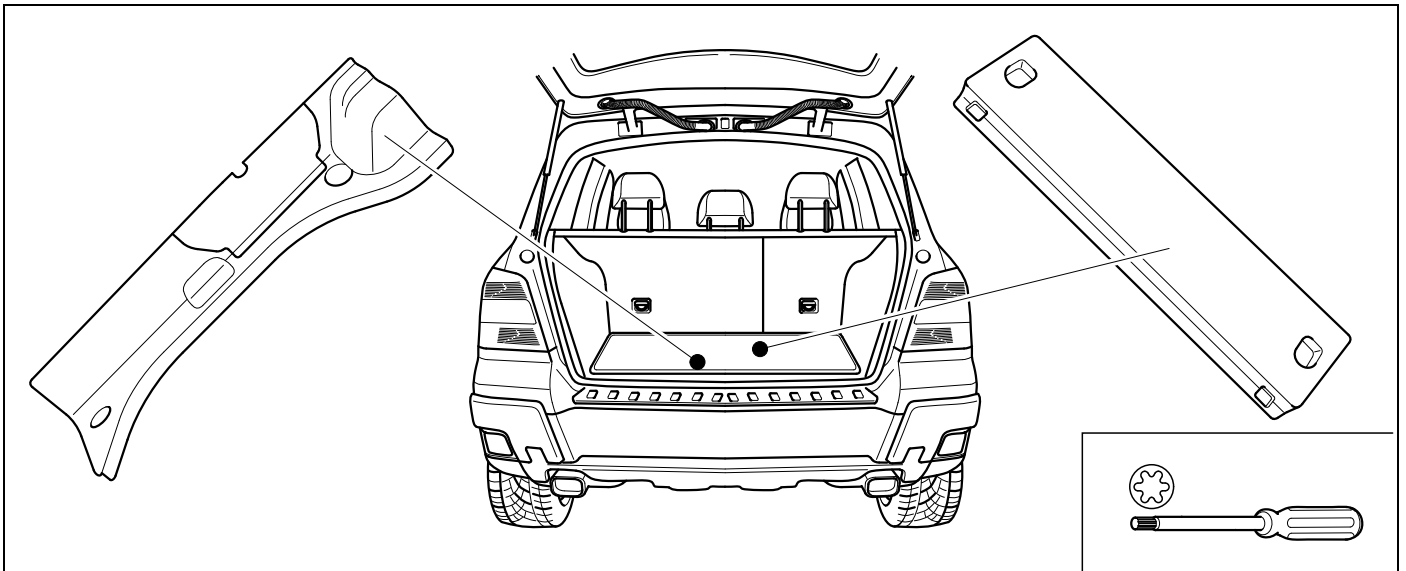

14

X 204

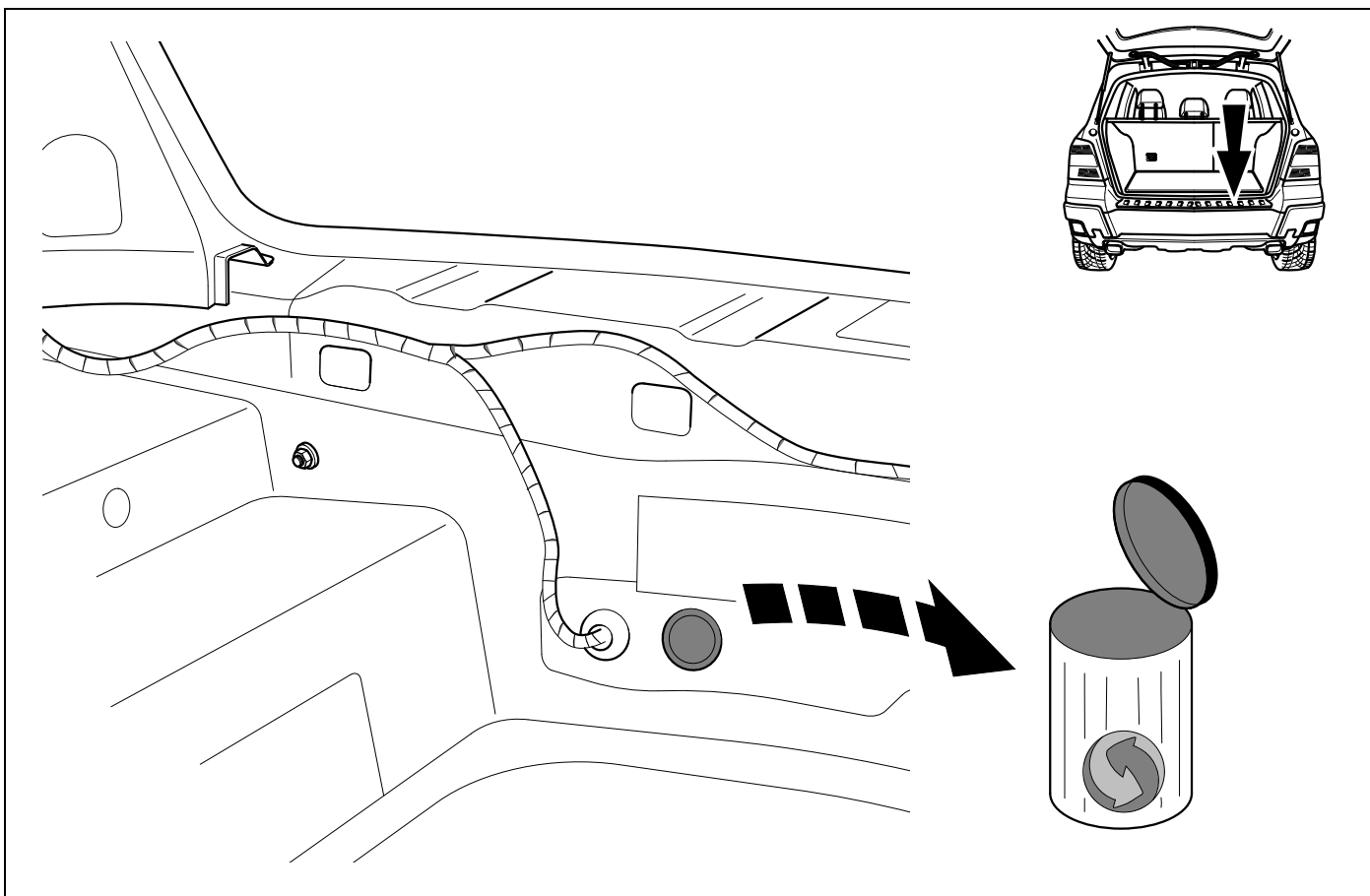

15

X 204

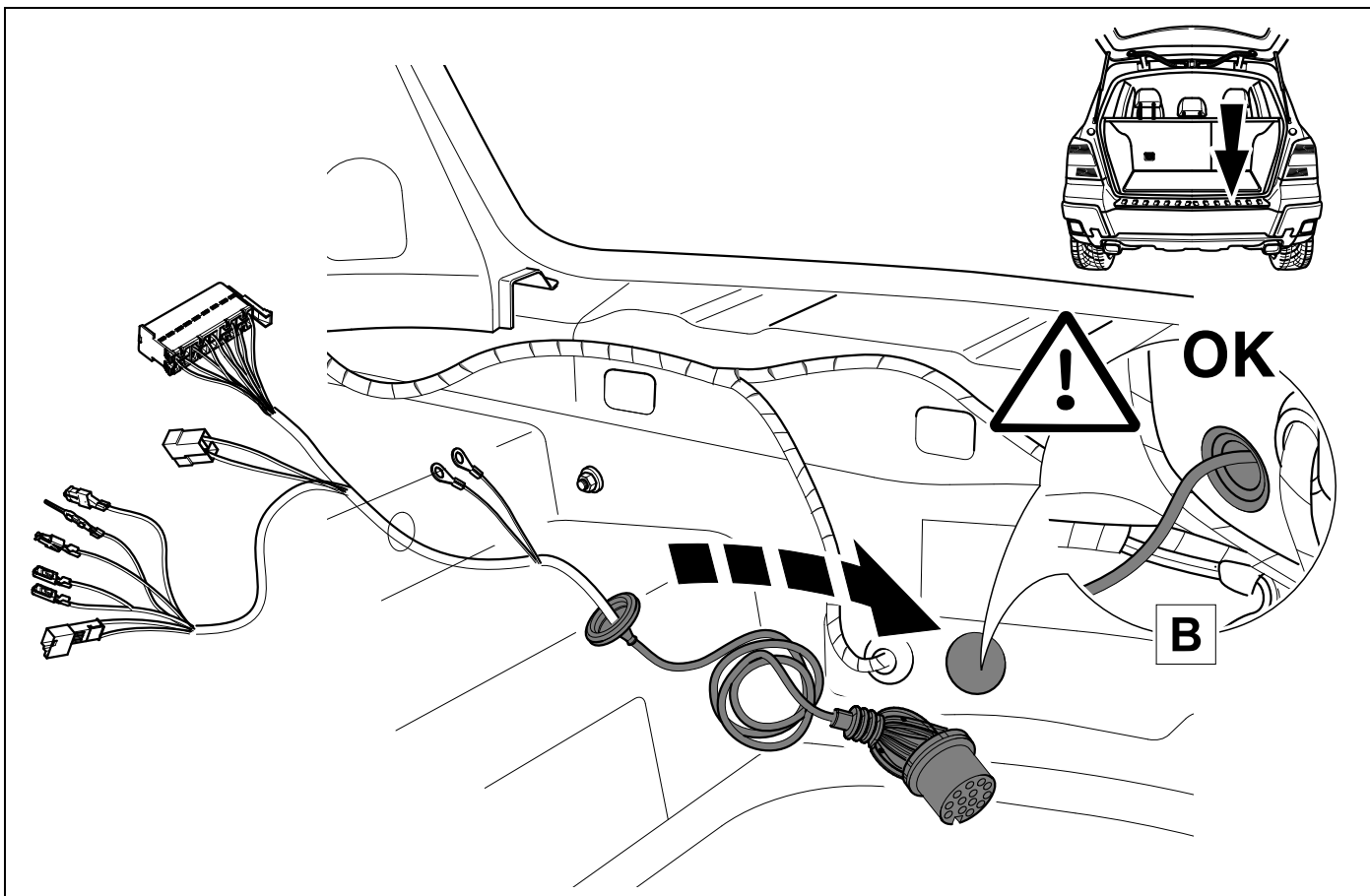

16

X 204

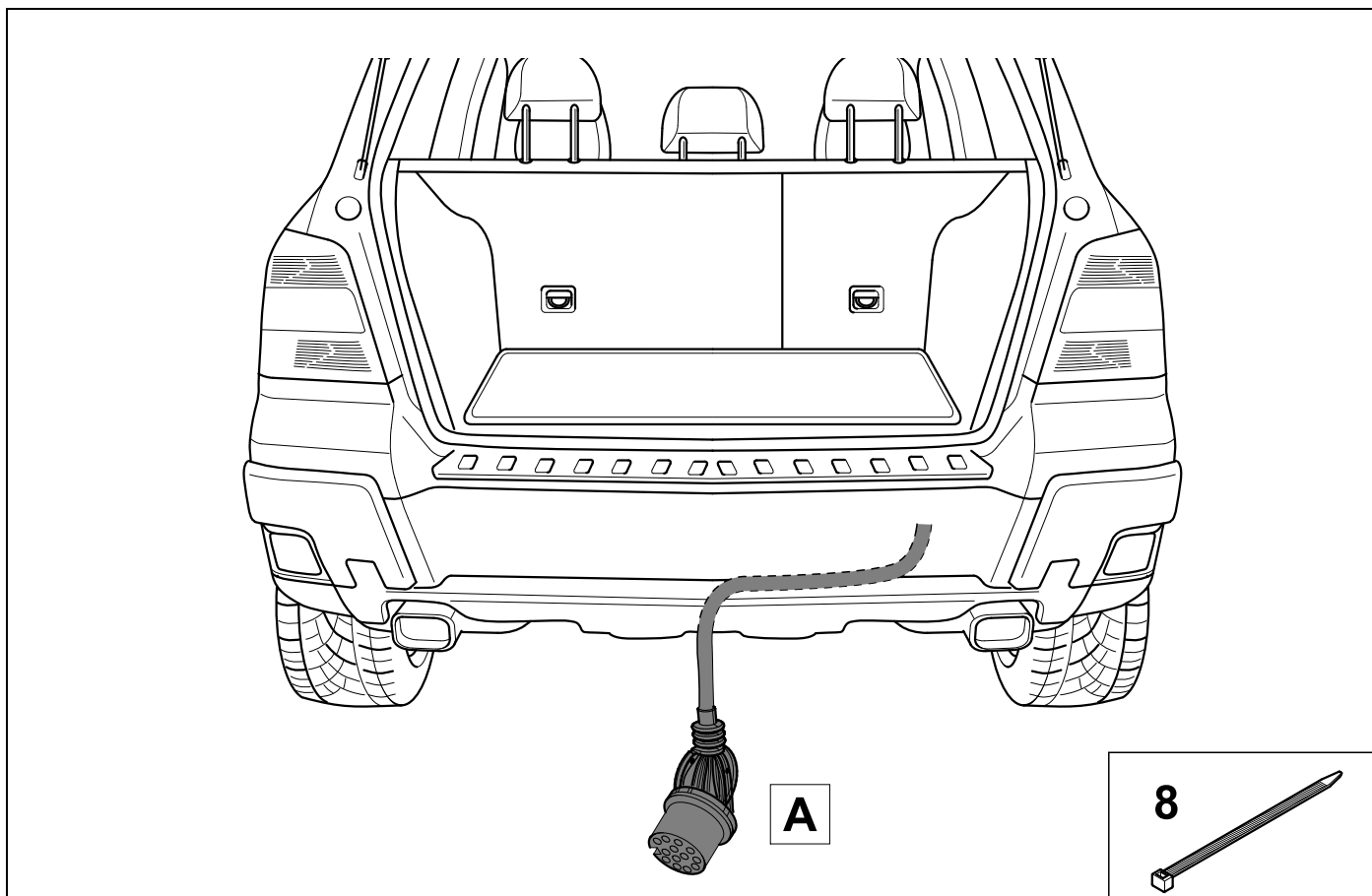

17

X 204

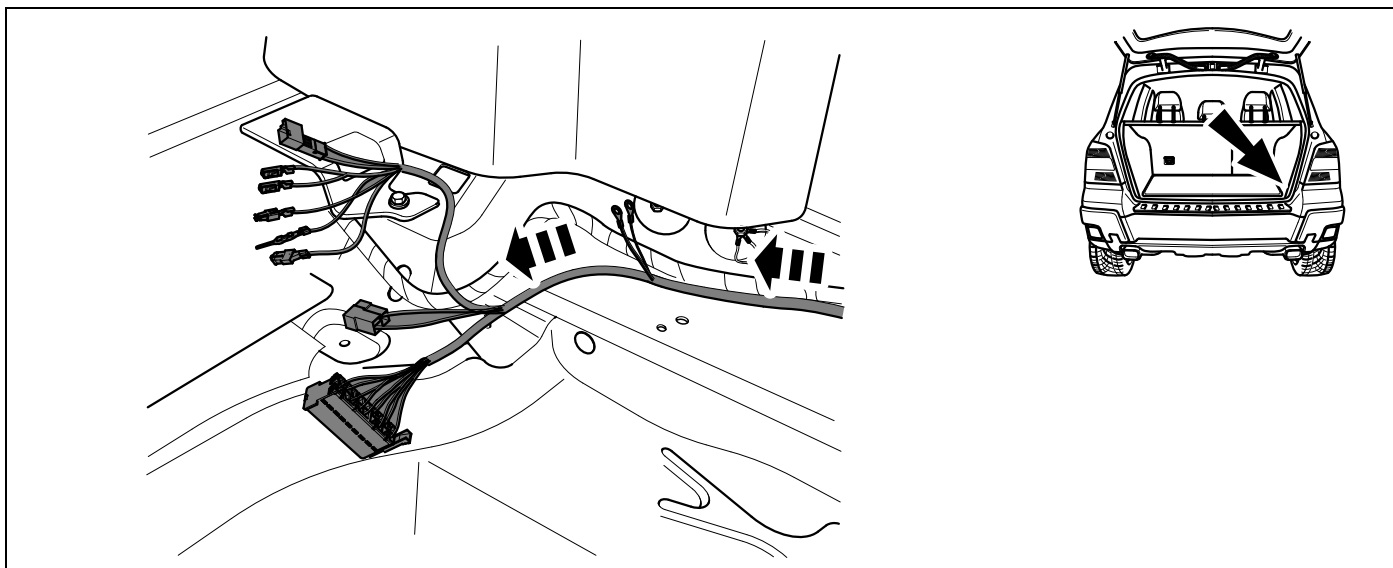

18

X 204

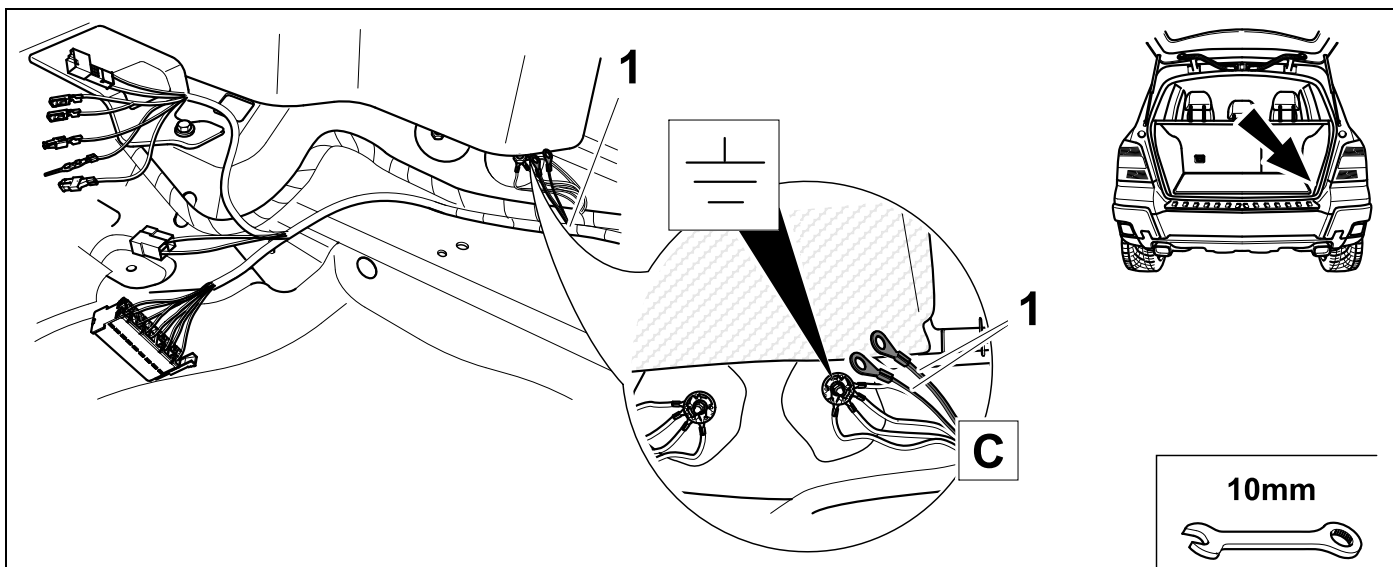

19

X 204

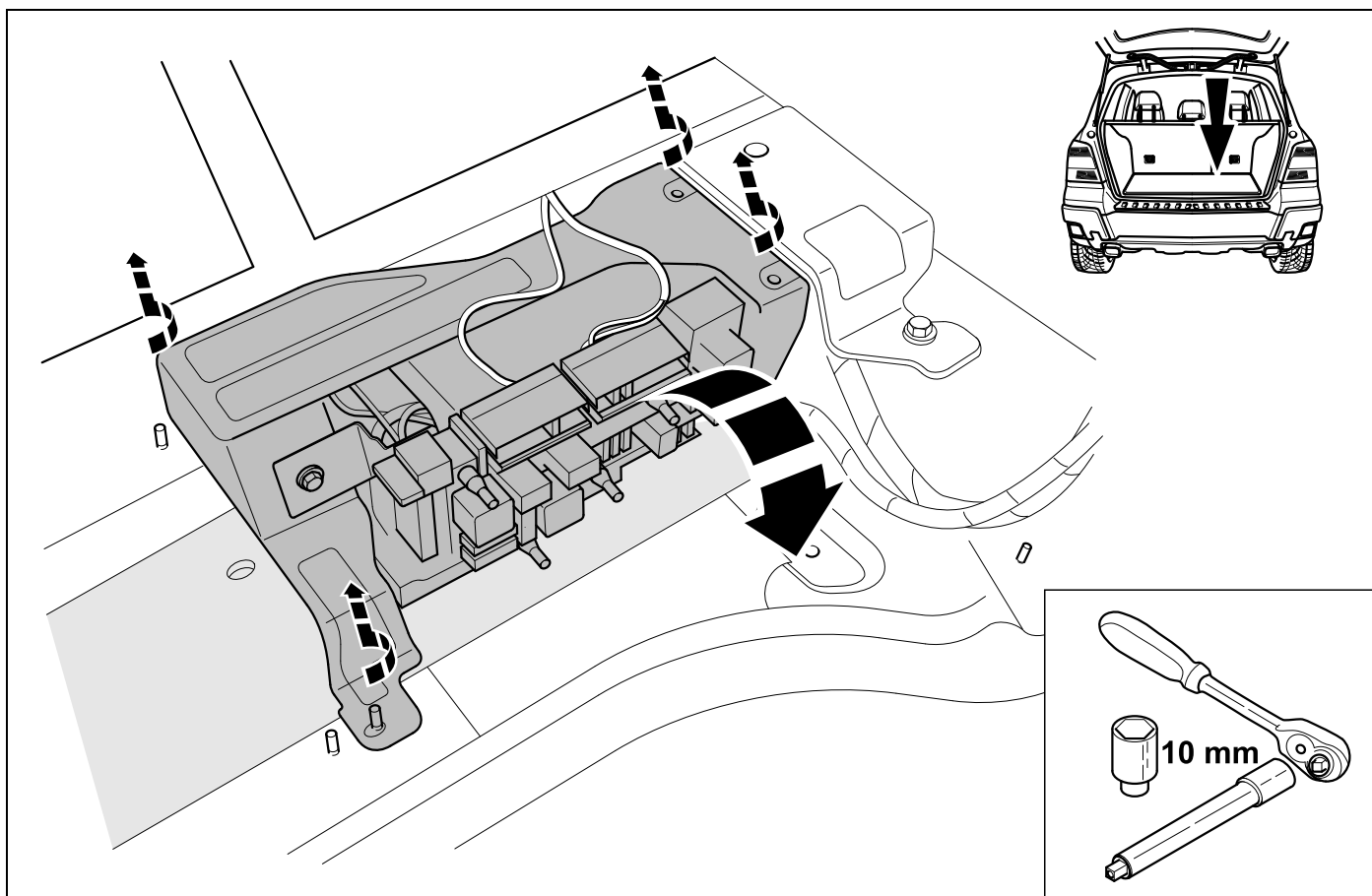

20

W/C 204 / S 204



42

X 204

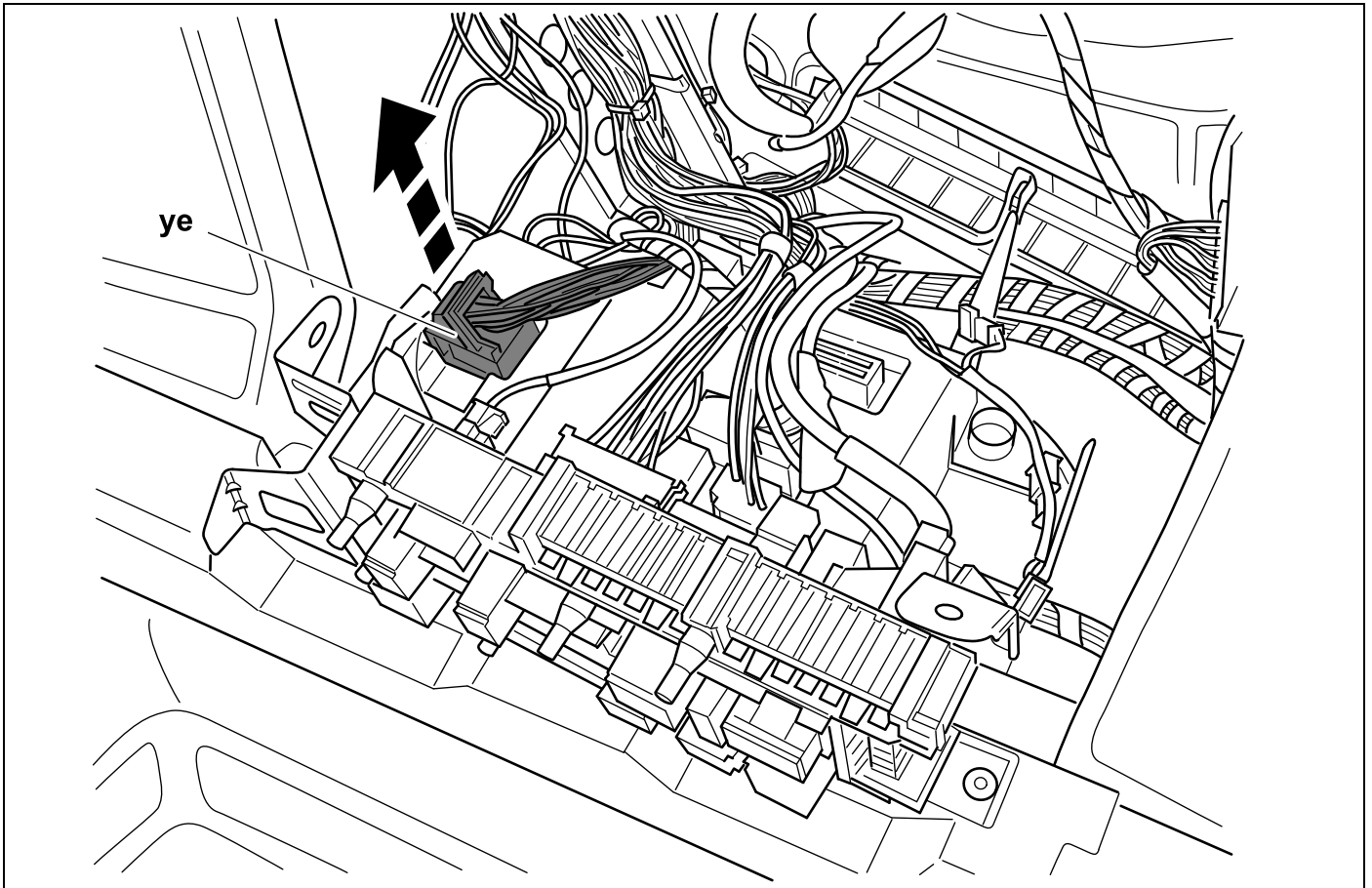

21

W/C 204 / S 204



42

X 204

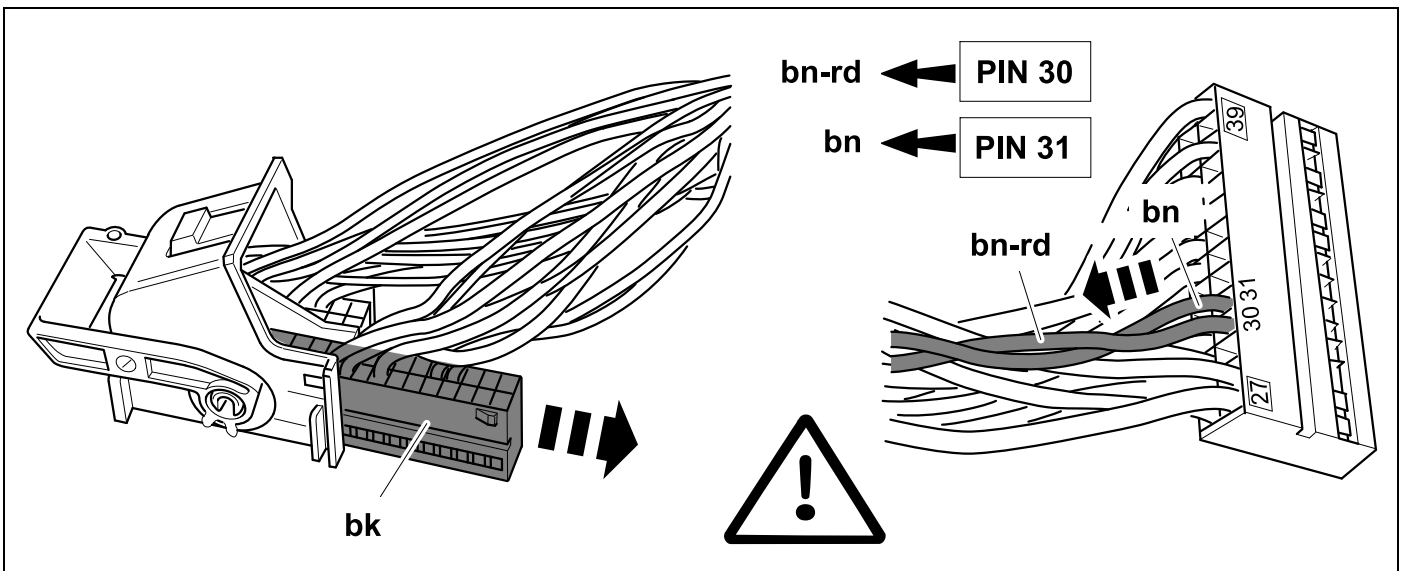



22

W/C 204 / S 204



42

X 204

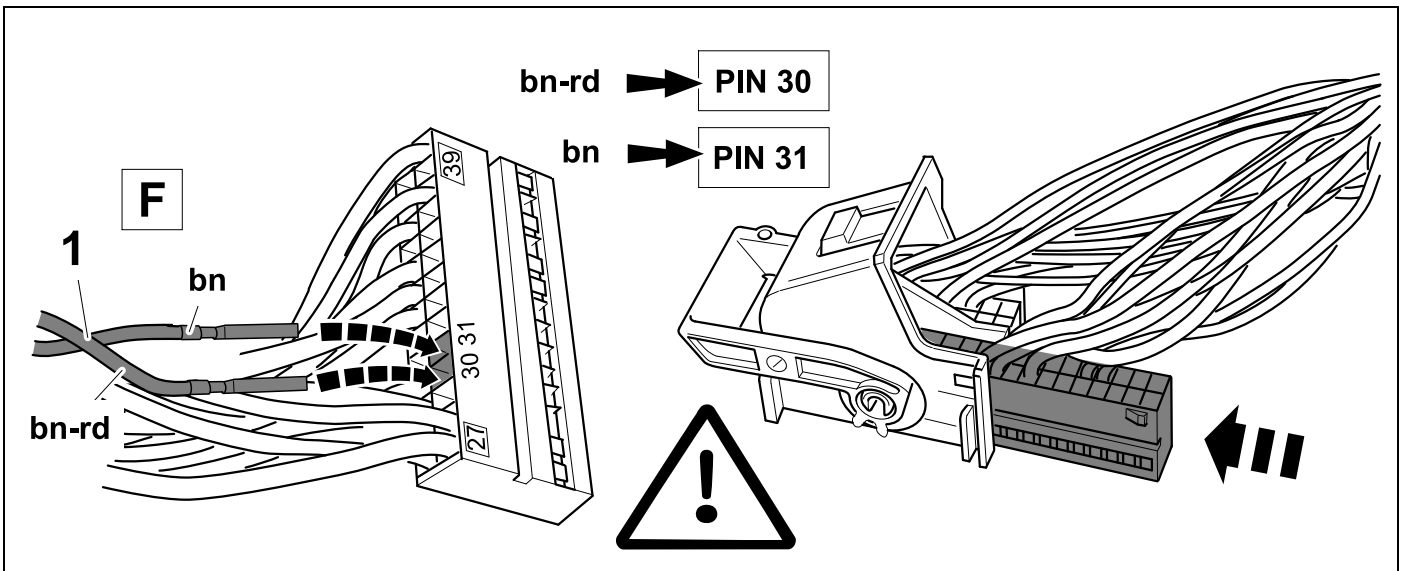

23

W/C 204 / S 204



42

X 204

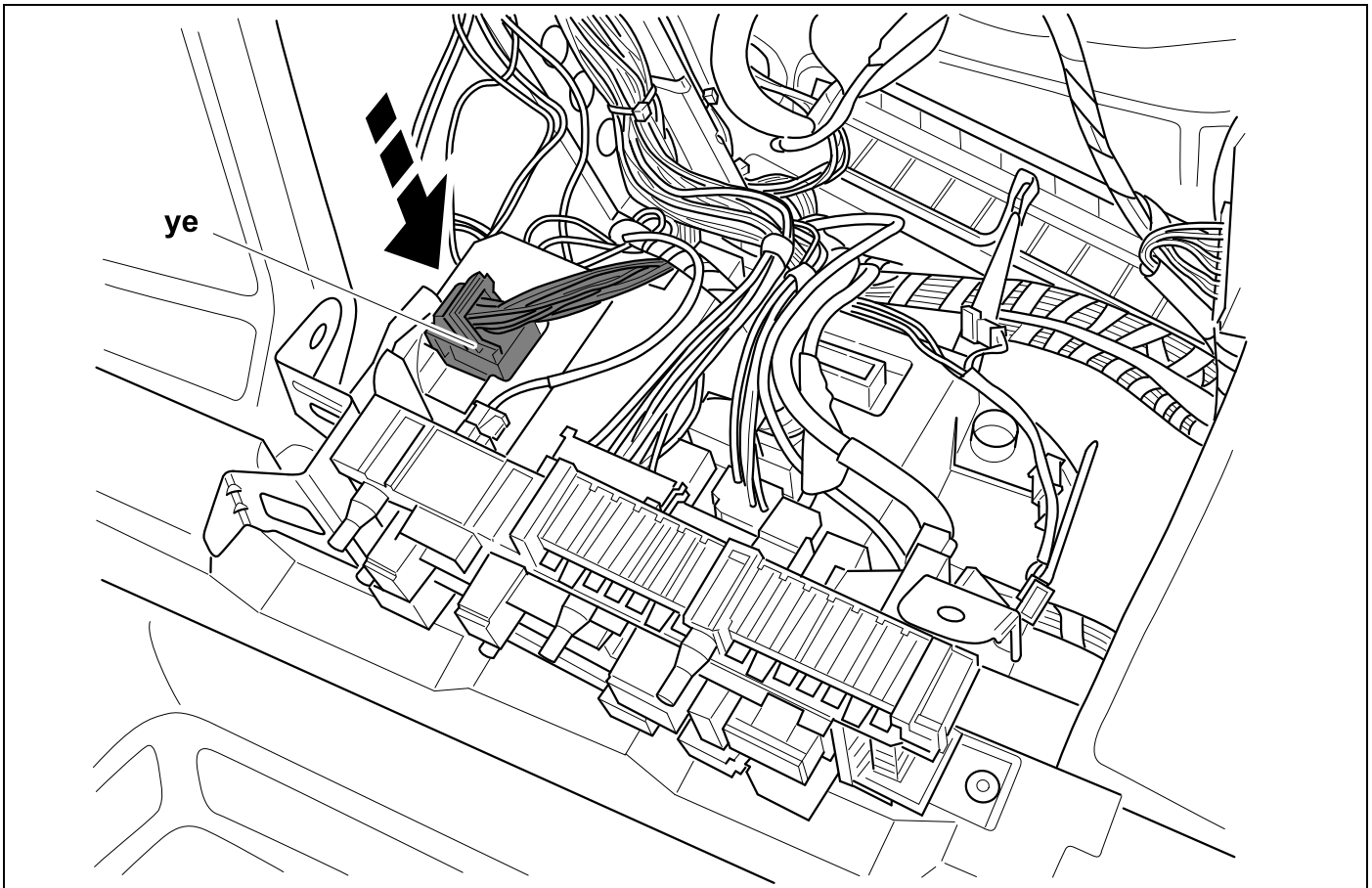

24

W/C 204 / S 204



42

X 204

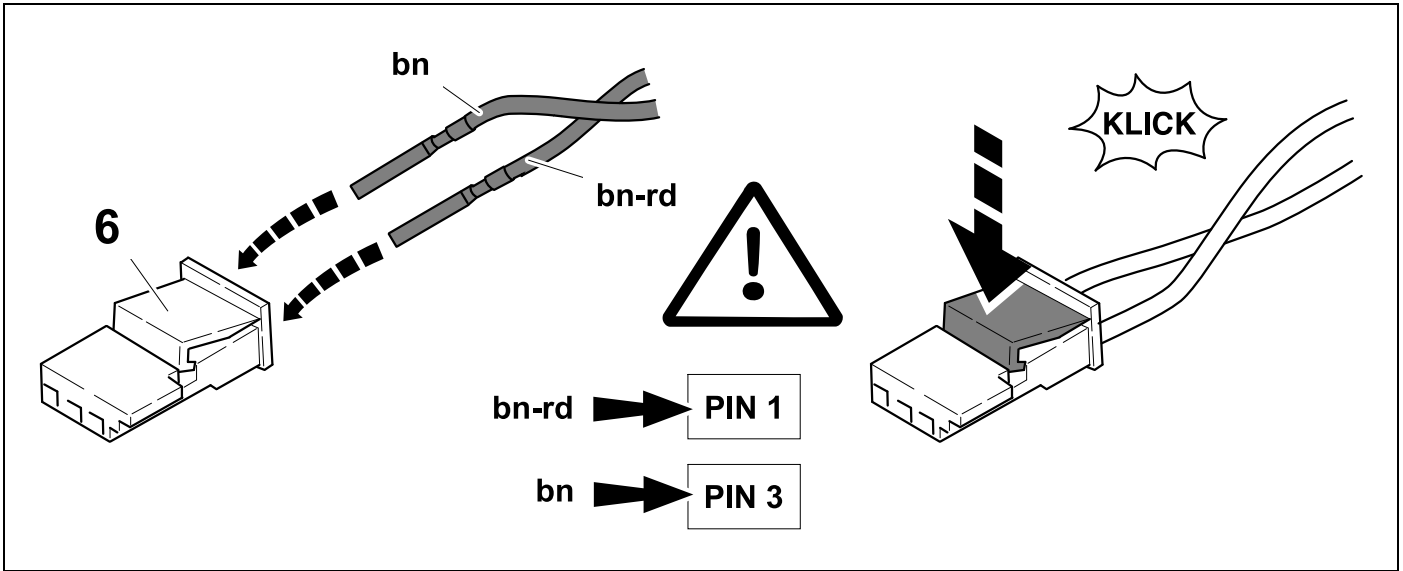

25

W/C 204 / S 204

X 204

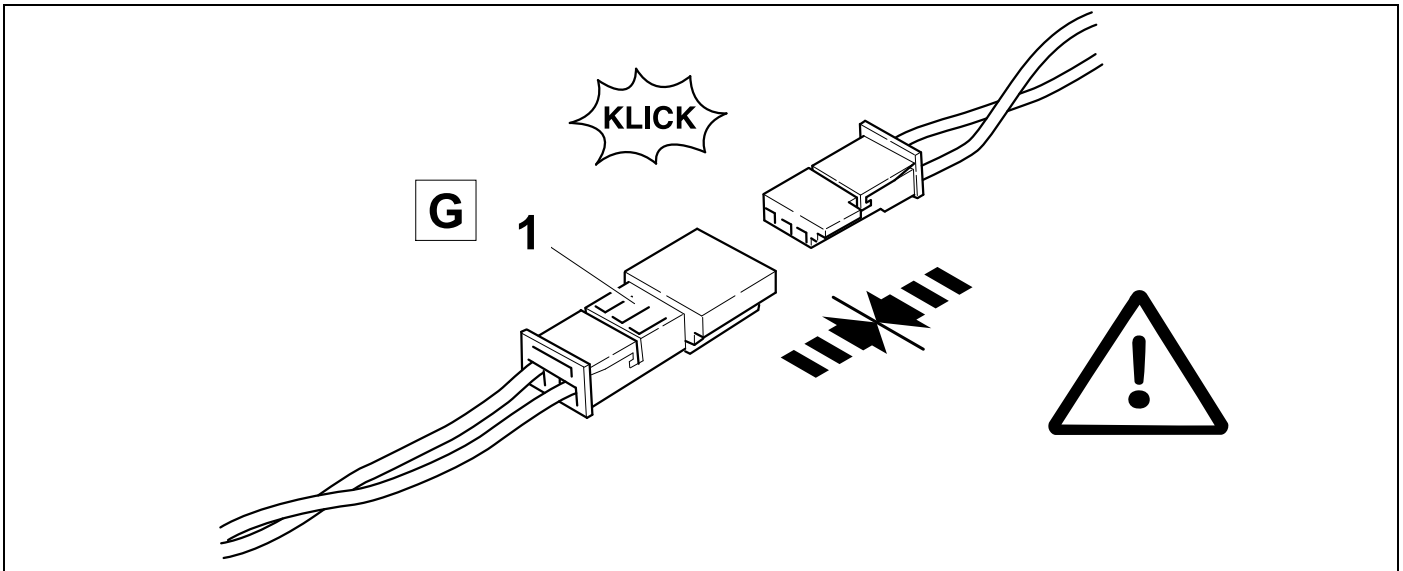

26

W/C 204 / S 204



53

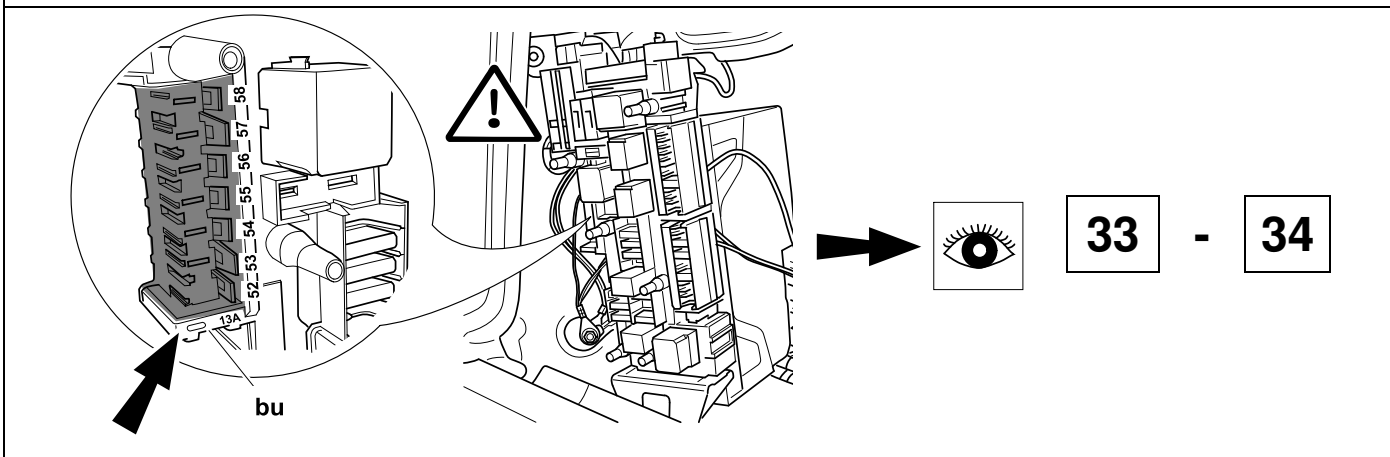
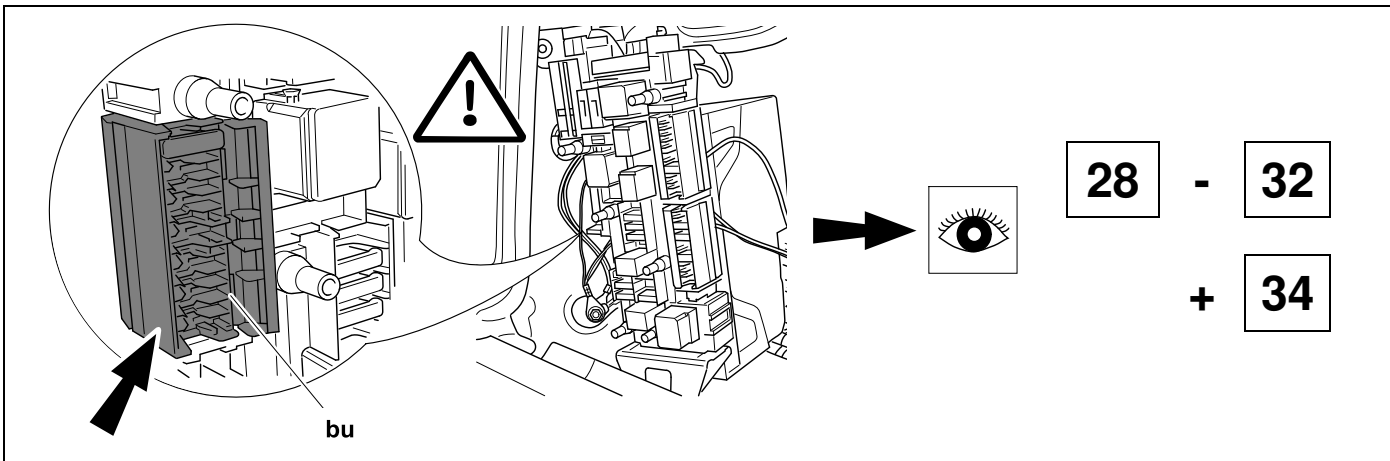

27



53

X 204

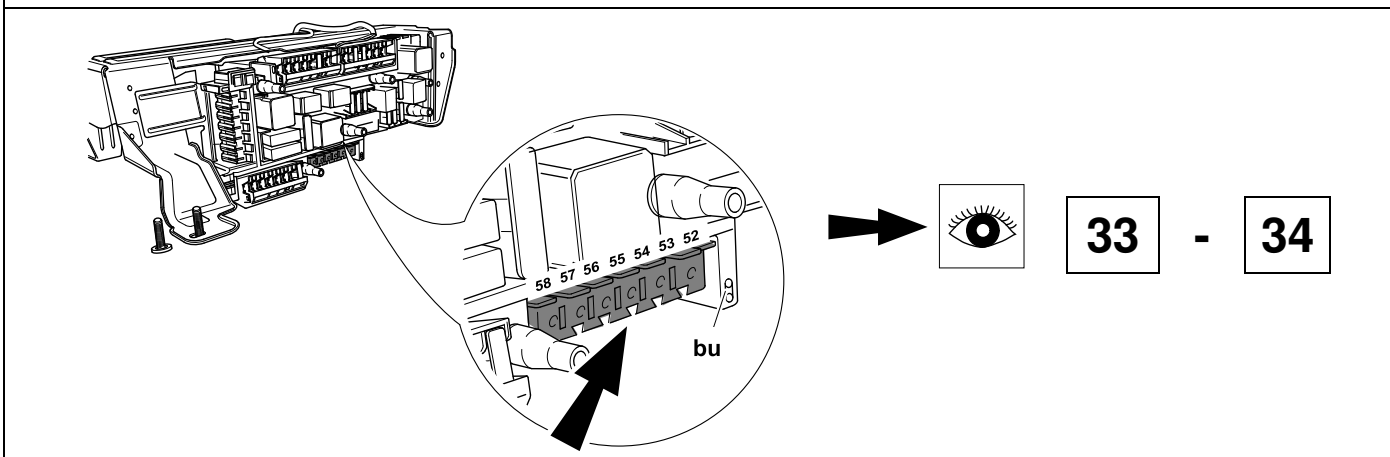
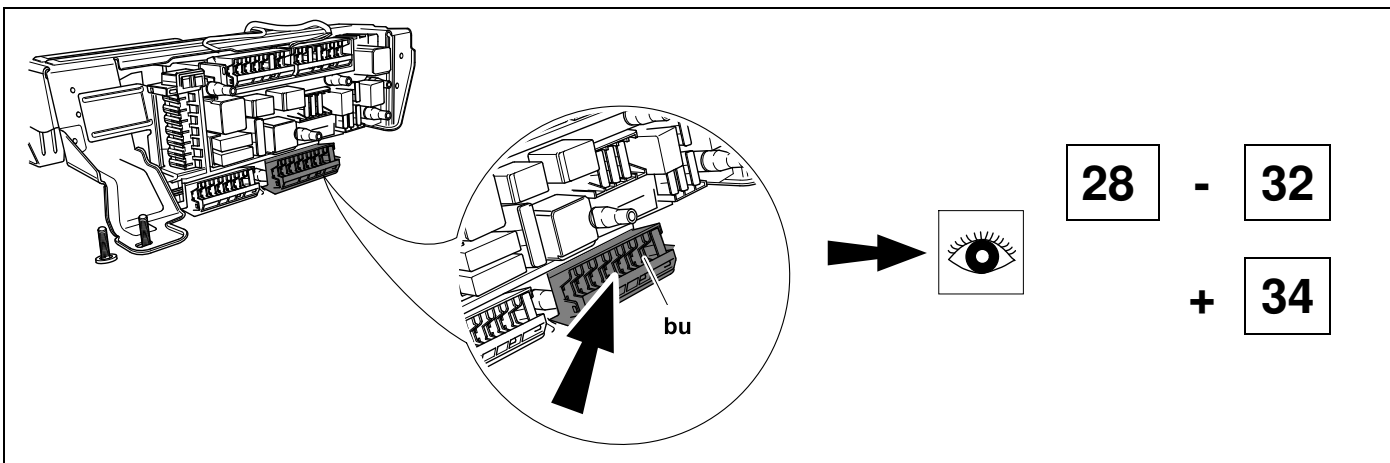

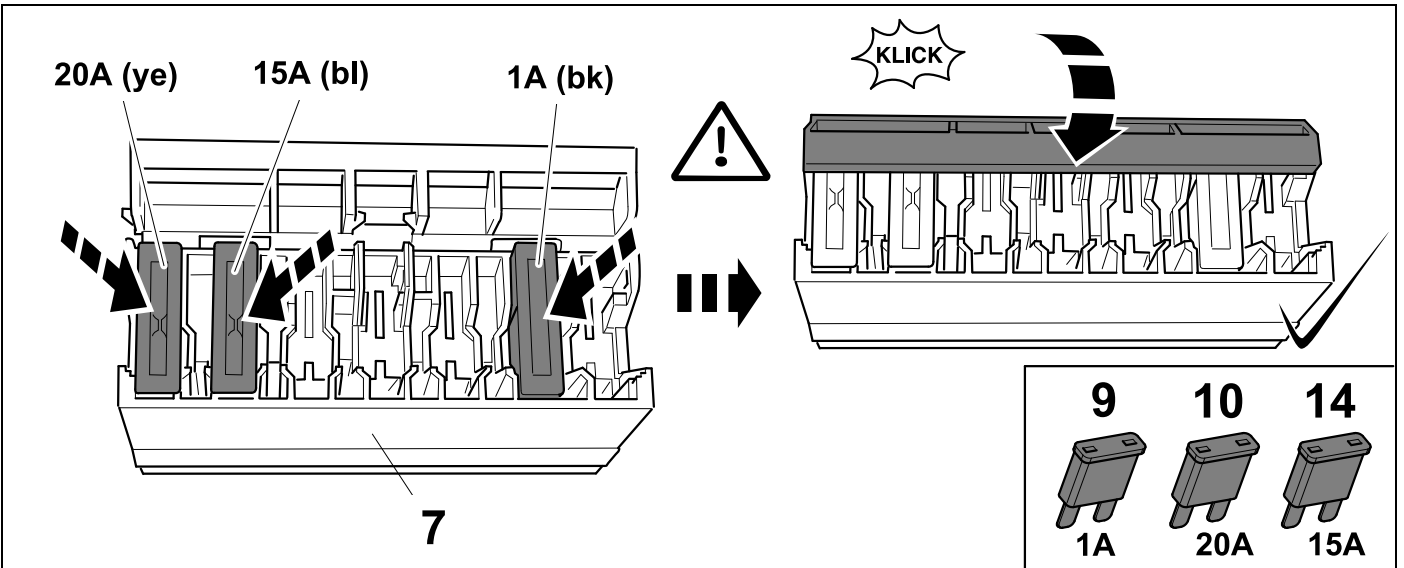
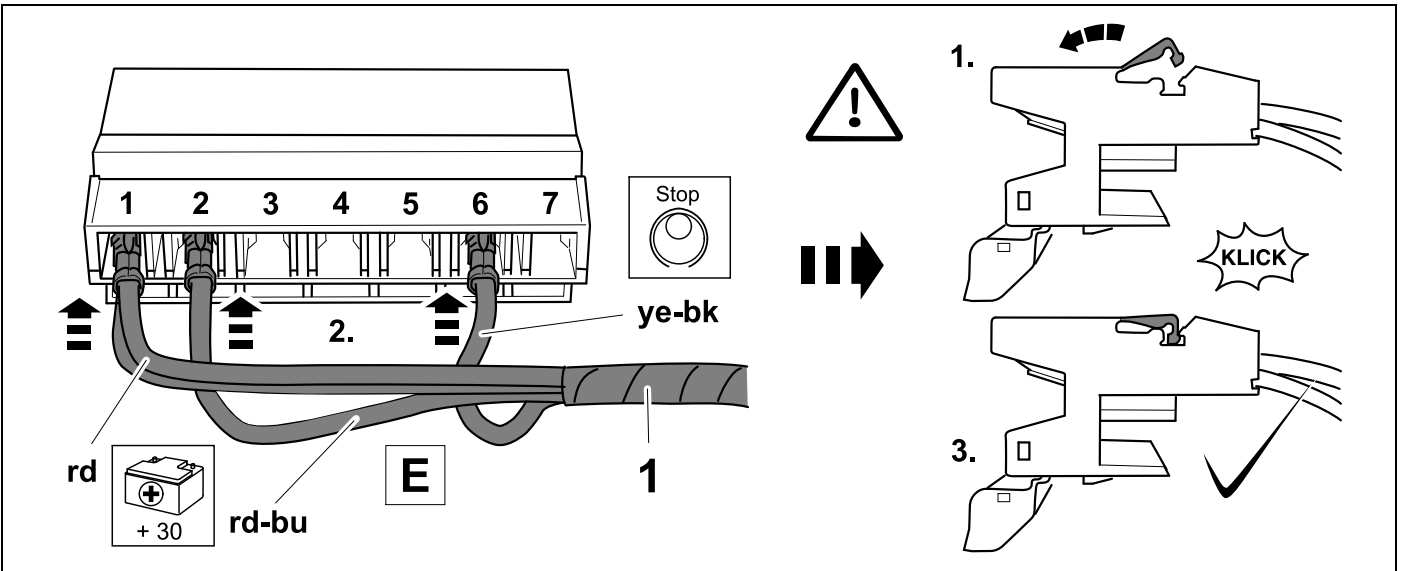
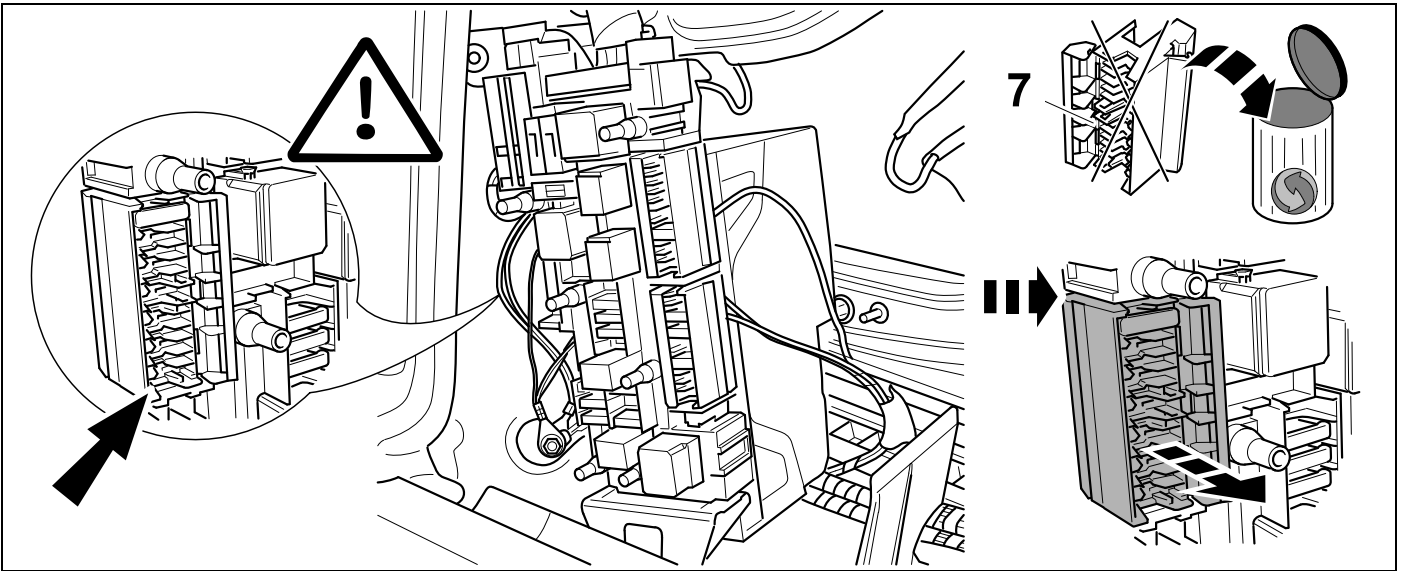

31



42

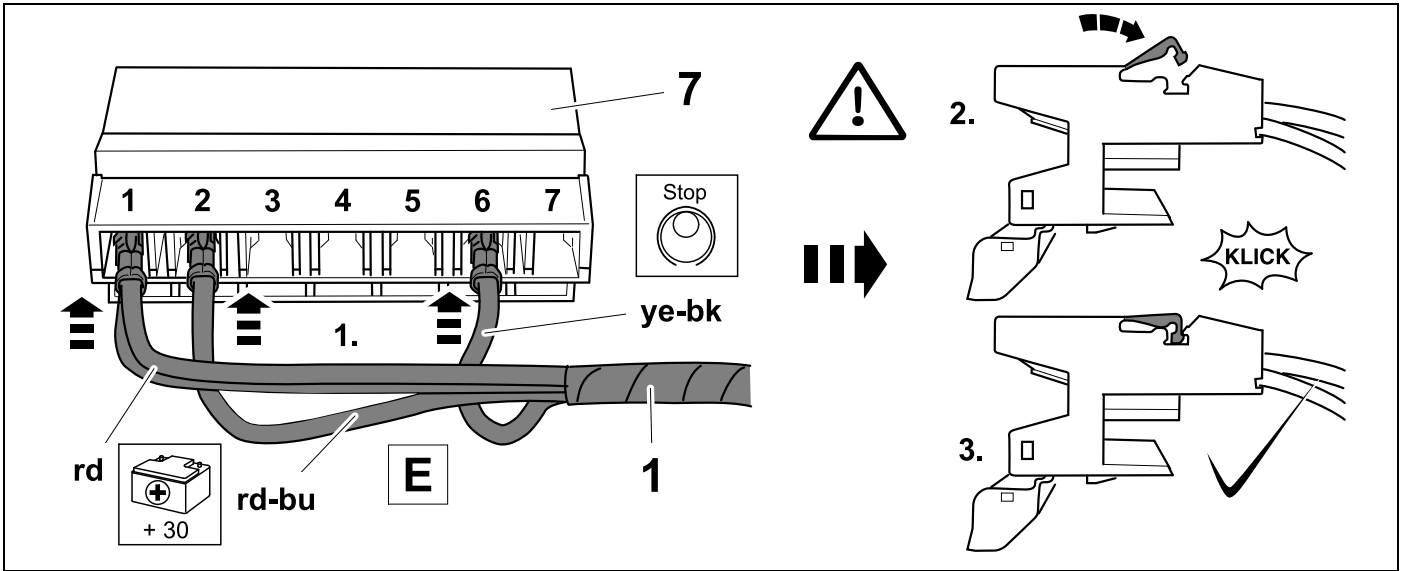

32



42

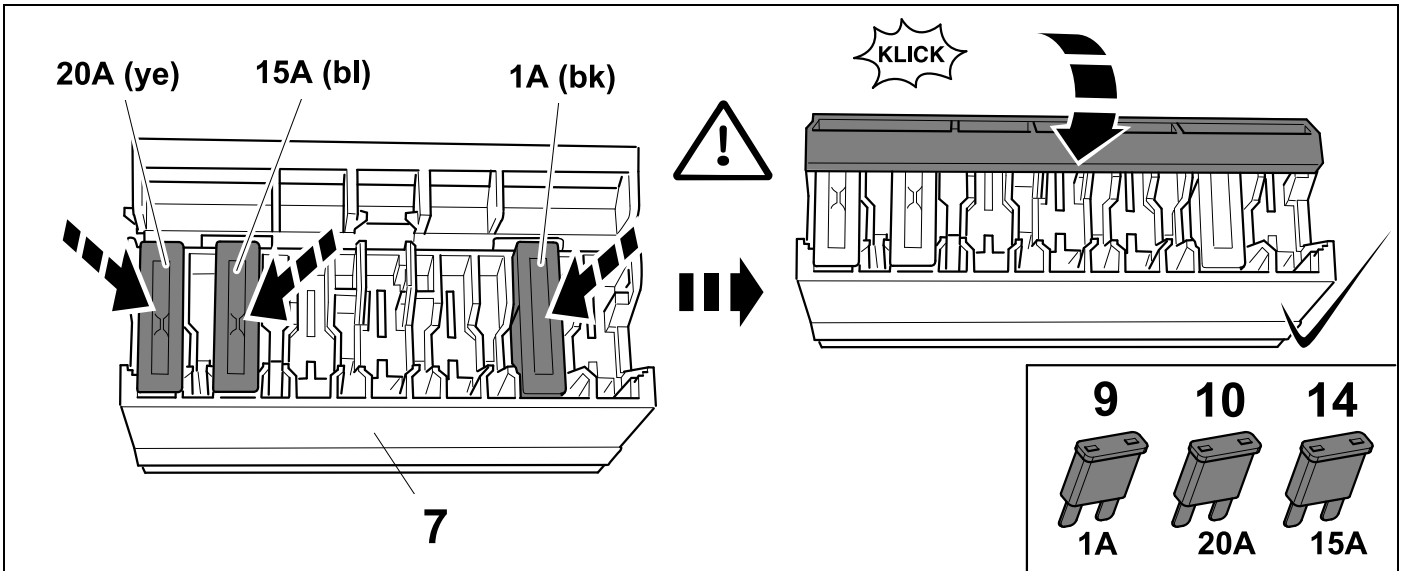

33

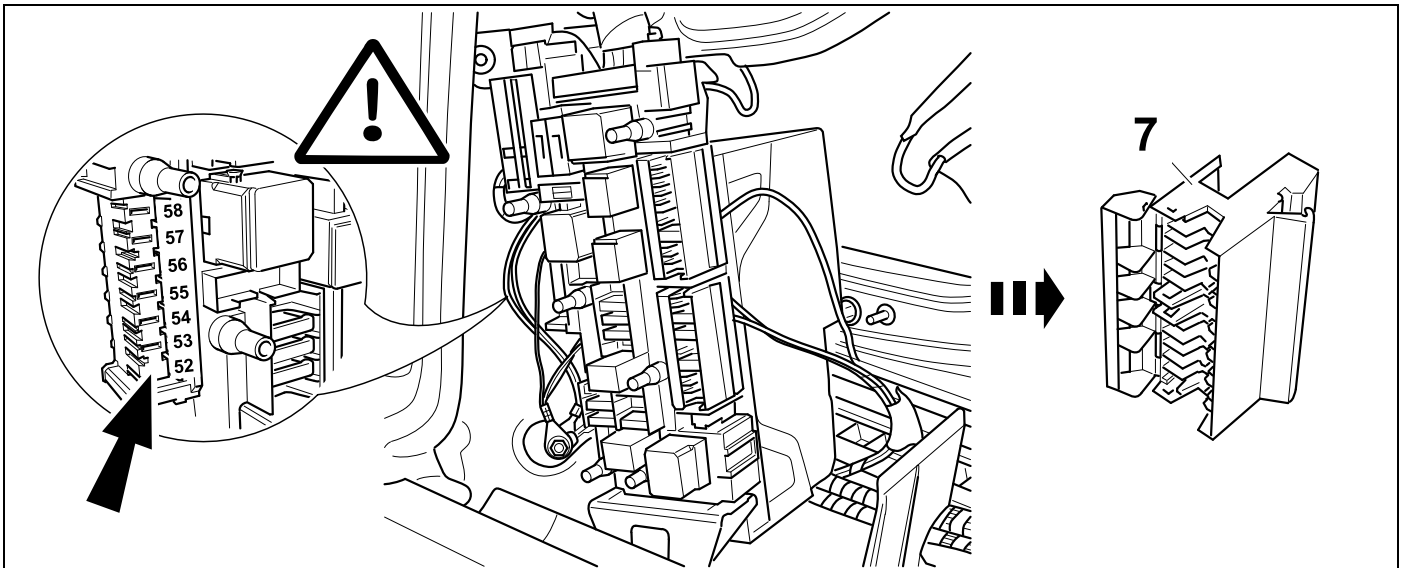

	<p><b>W/C 204</b></p>			<p>35 - 37</p>
	<p><b>S 204</b></p>			<p>35 - 37</p>
	<p><b>X 204</b></p>			<p>38 - 49</p>

**W/C 204 / S 204**

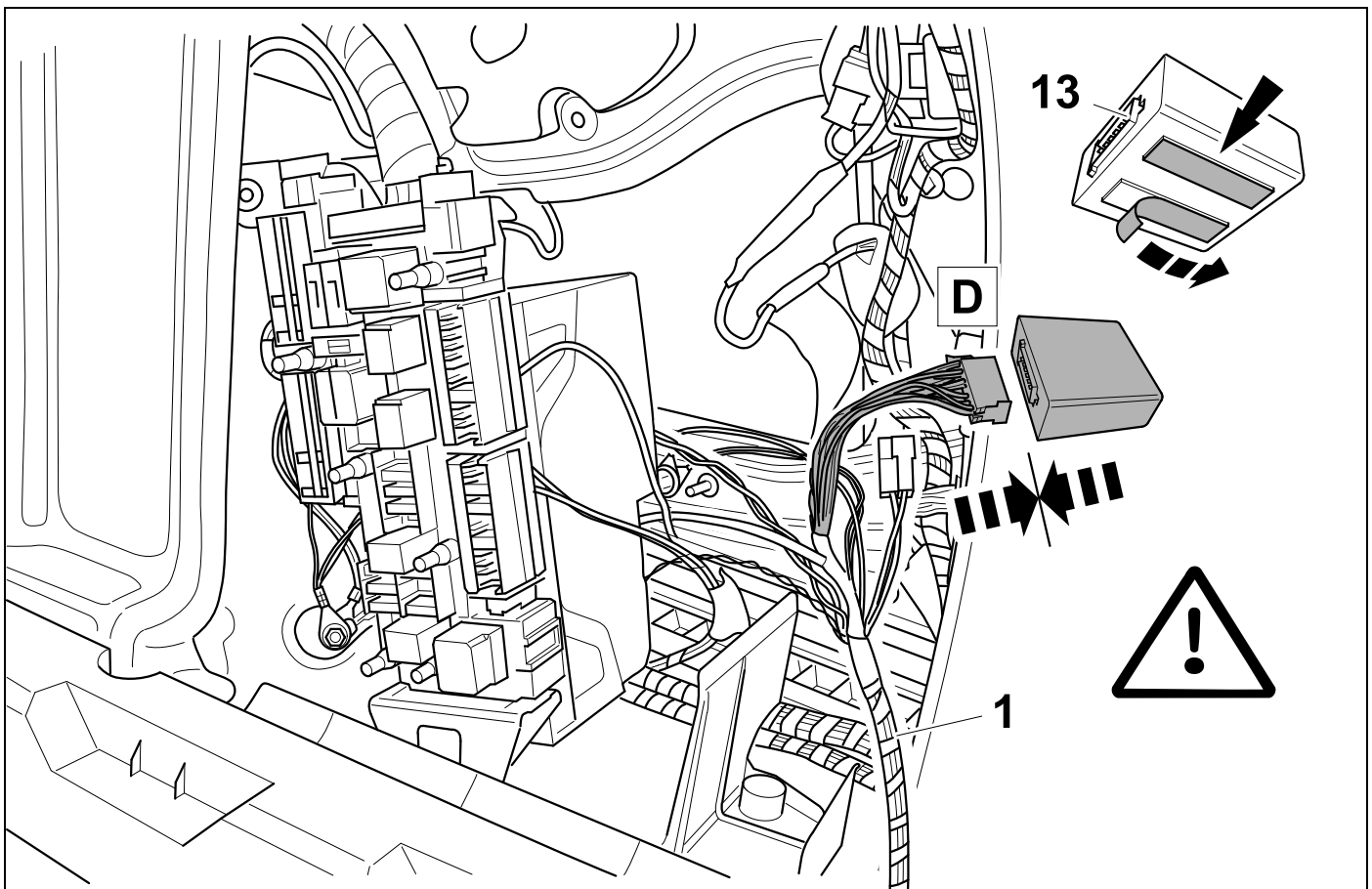

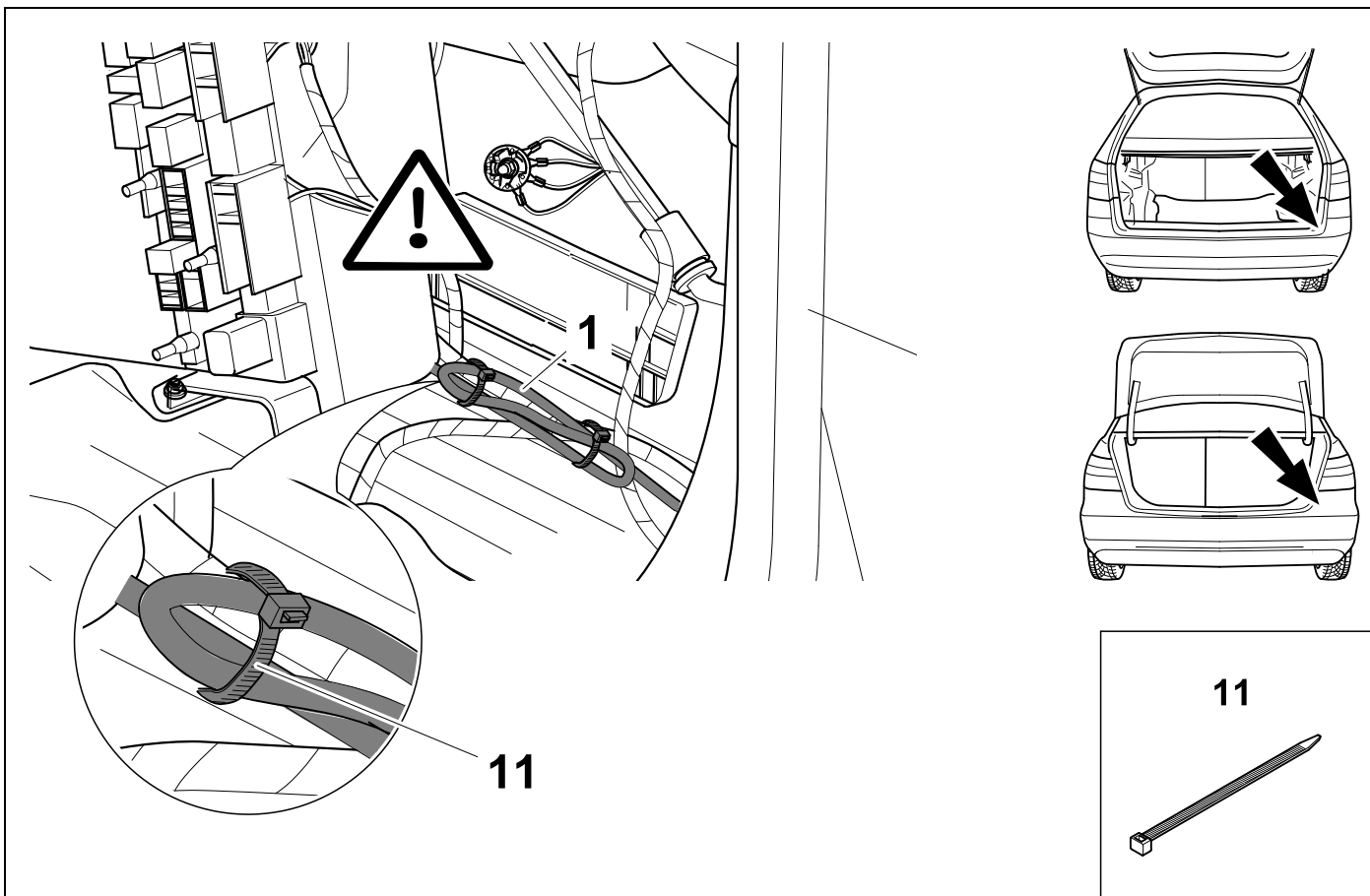
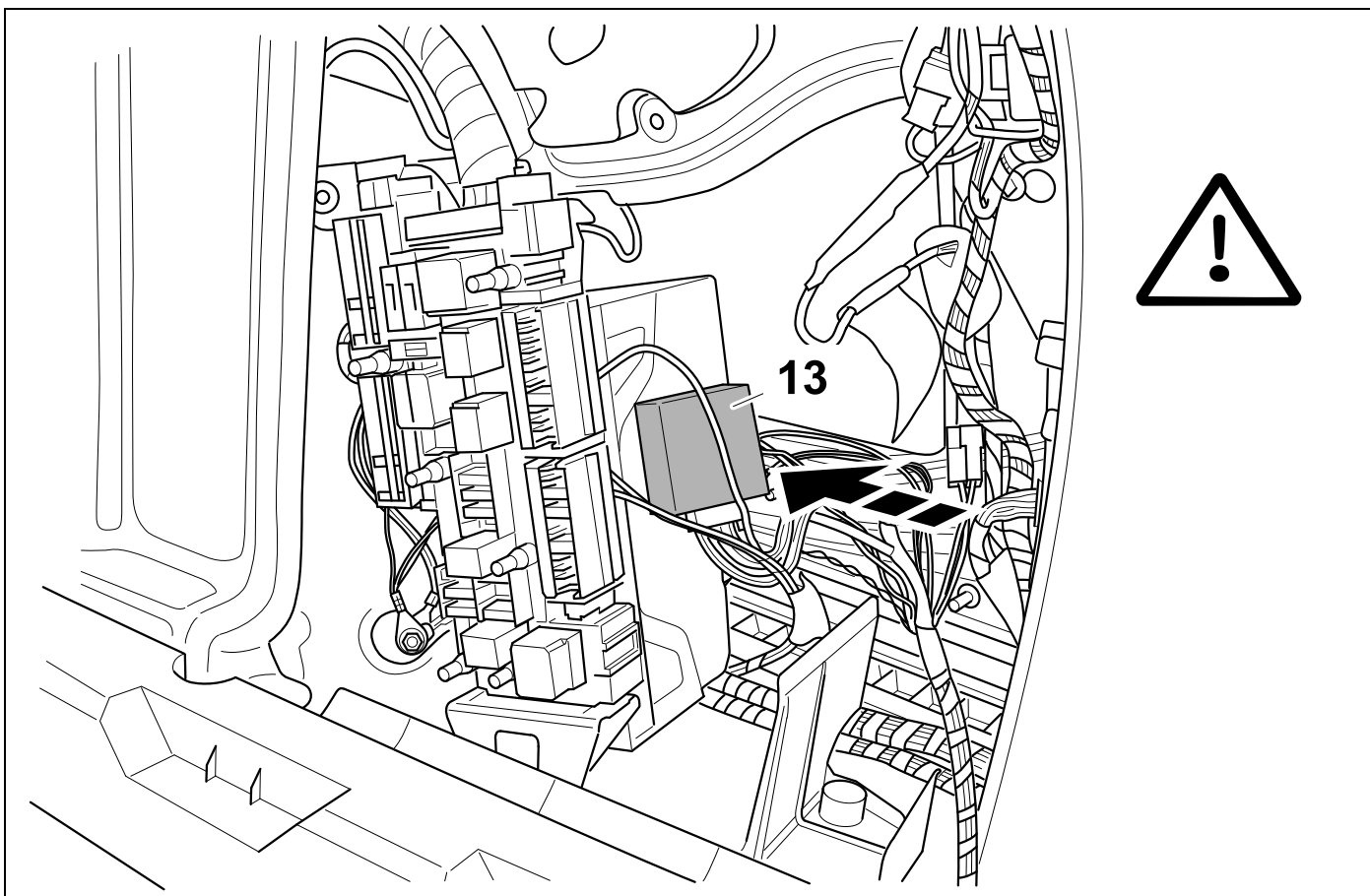

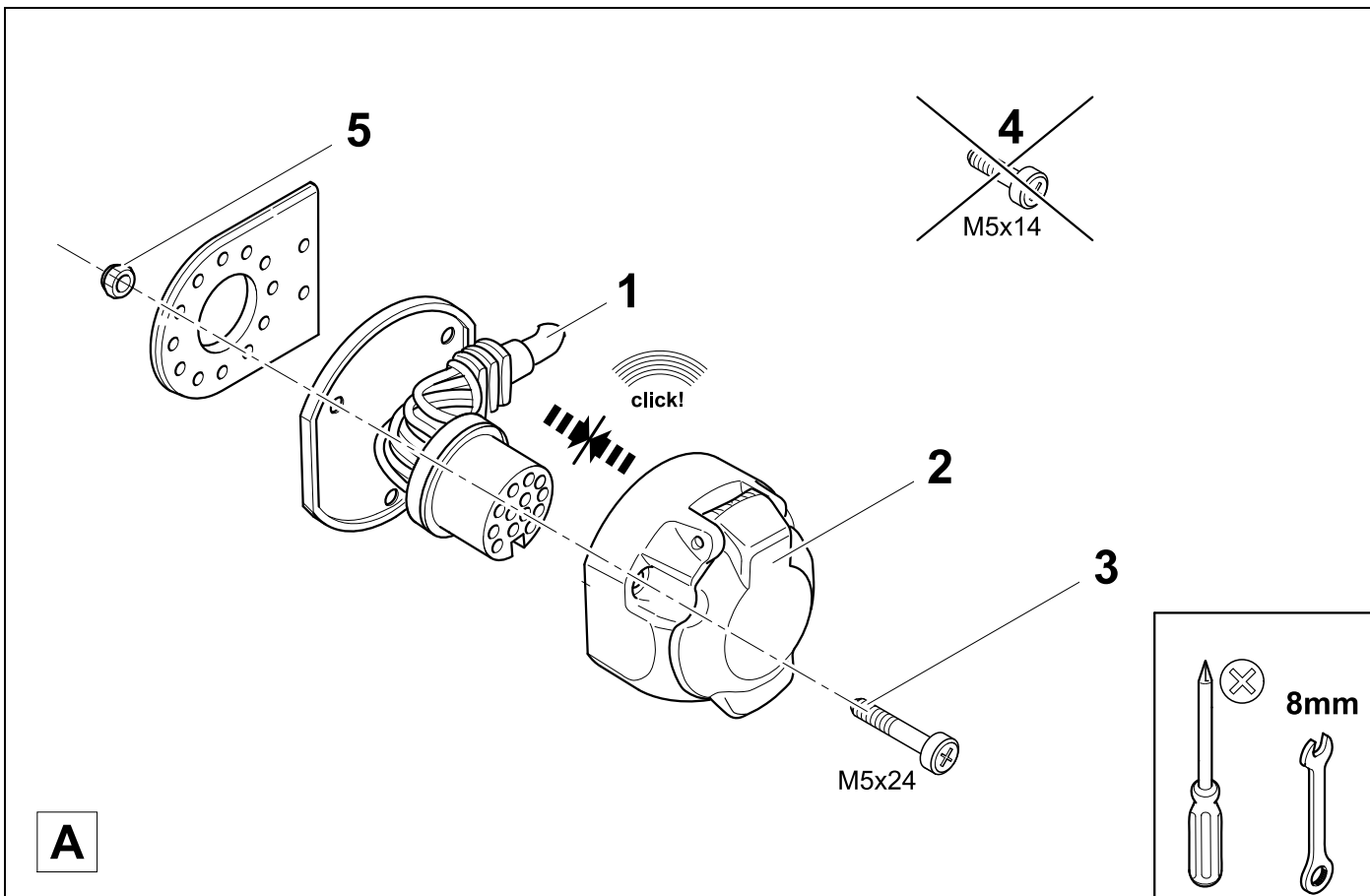
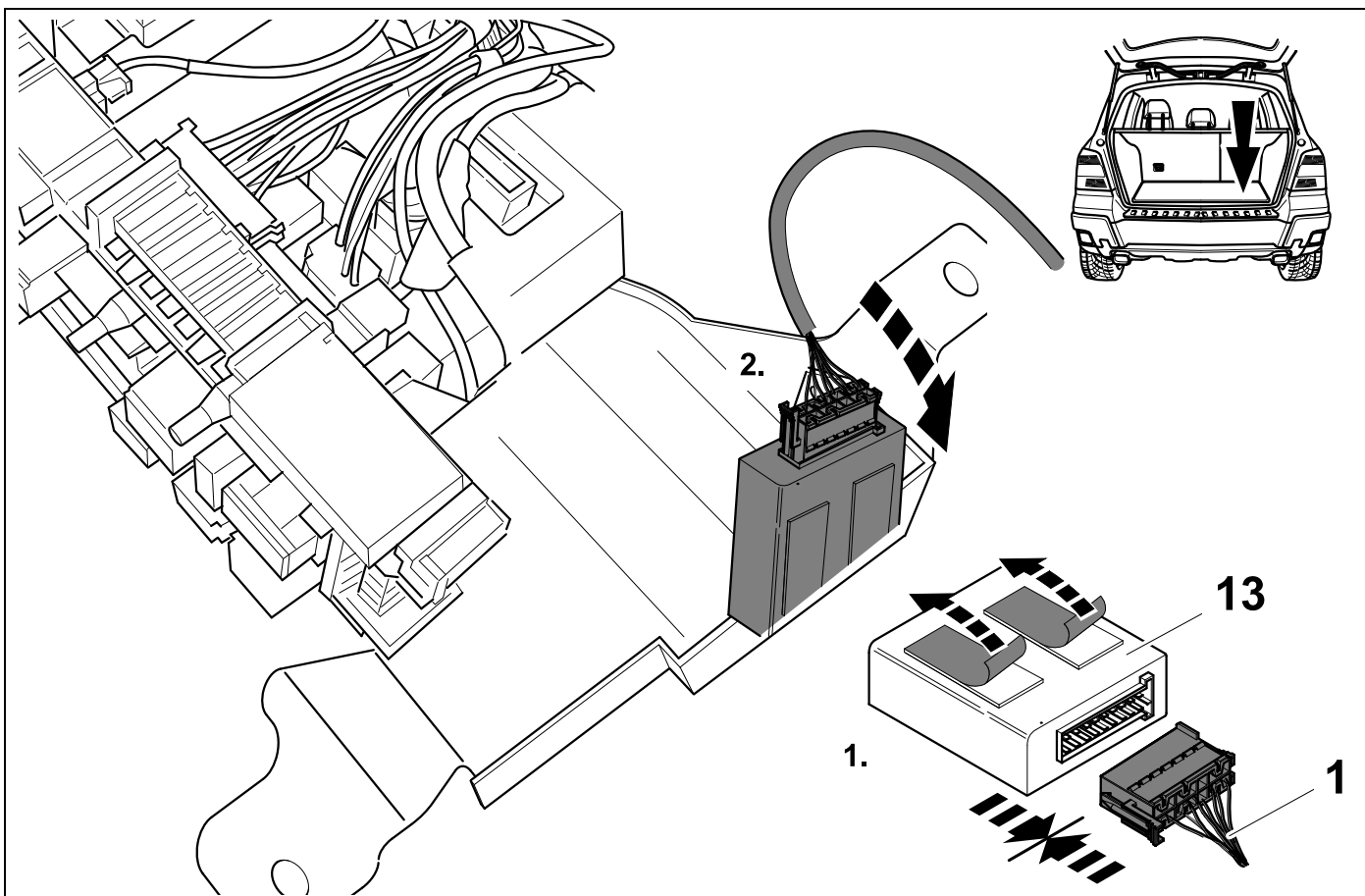

A



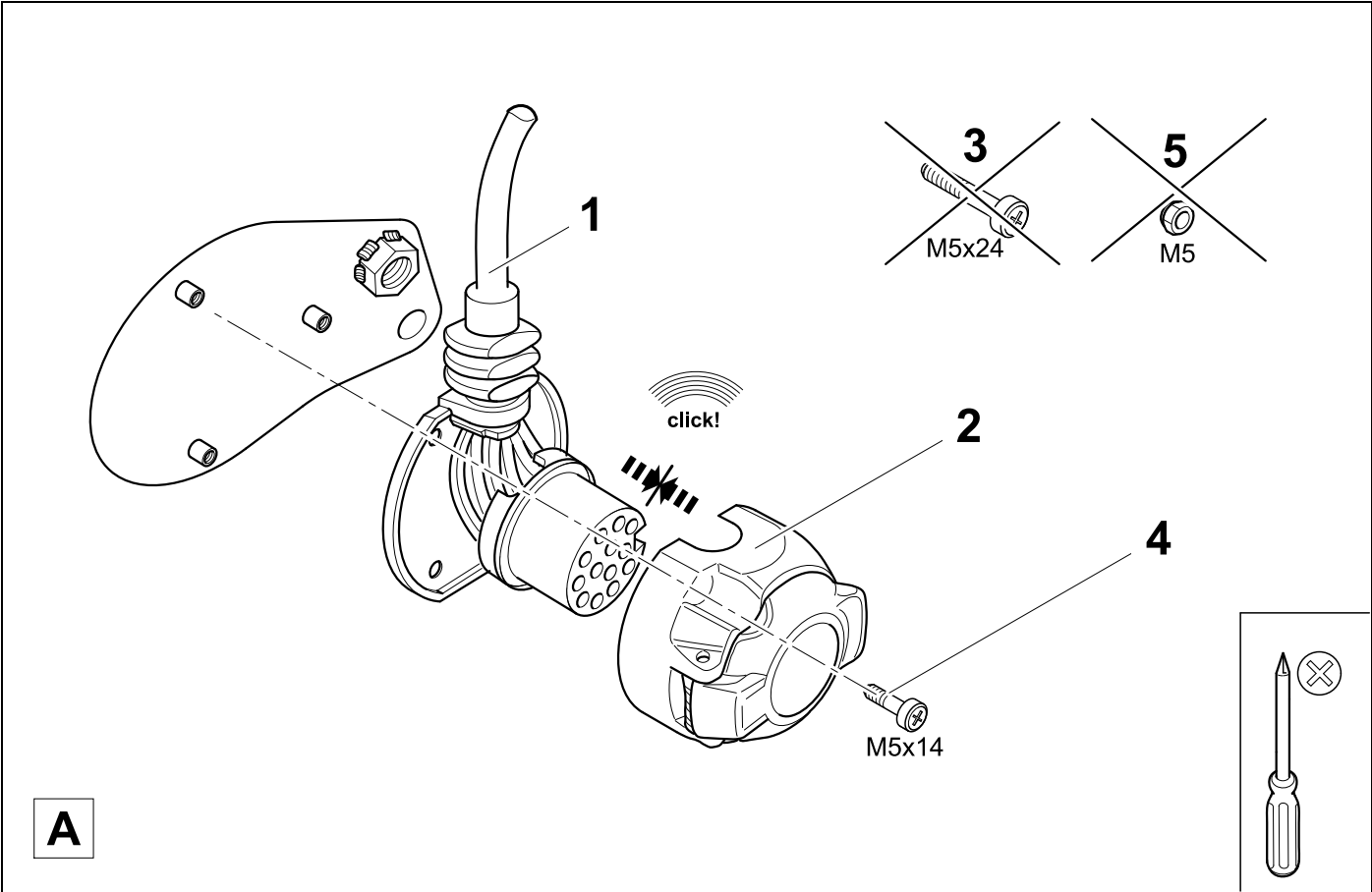





13 Pin			13 Pin		
1	bk/wh			bu/rd	8
2	gy			rd/bu	9
3	bn			ye	10
4	bk/gn			bn/gn	11
5	gy/rd		-/-	no	12
6	bk/rd			bn	13
7	gy/bk				

42	bk	wh	gy	gn	rd	bu	ye	bn	pu	or	no
(D)	schwarz	weiß	grau	grün	rot	blau	gelb	braun	violett	orange	nicht belegt
(GB)	black	white	grey	green	red	blue	yellow	brown	purple	orange	not occupied
(F)	noir	blanc	gris	vert	rouge	bleu	jaune	brun	violet	orange	inutilisé
(NL)	zwart	wit	grijs	groen	rood	blauw	geel	bruin	violet	oranje	niet aangesloten
(DK)	sort	hvid	grå	grøn	rød	blå	gul	brun	violet	orange	ikke anvendt
(N)	svart	hvit	grå	grønn	rød	blå	gul	brun	fiolett	oransje	ikke i bruk
(S)	svart	vit	grå	grön	röd	blå	gul	brun	violett	orange	ej använd
(FIN)	musta	valkoinen	harmaa	vihreä	punainen	sininen	keltainen	ruskea	violetti	oranssi	ei varattu
(I)	nero	bianco	grigio	verde	rosso	blu	giallo	marrone	viola	arancione	libero
(E)	negro	blanco	gris	verde	rojo	azul	amarillo	marrón	violeta	anaranja-do	no ocupado
(P)	preto	branco	cinzento	verde	vermelho	azul	amarelo	castanho	violeta	laranja	não ocupado
(GR)	μαύρος	λευκός	Γκρι	πράσινος	κόκκινος	μπλε	κίτρινος	καφέ	Μωβ	πορτοκαλί	δεν είναι κατ'επιλημμένος
(PL)	czarny	biały	szary	zielony	czerwony	niebiesko	żółty	brazowy	fioletowy	pomarańczowy	wolny
(CZ)	černý	bílý	šedý	zelený	červený	modrý	žlutý	hnědý	fialový	oranžový	neobsazen
(TR)	siyah	beyaz	gri	yeşil	kırmızı	mavi	sarı	kahverengi	mor	portakal rengi	boş
(H)	fekete	fehér	szürke	zöld	piros	kék	sárga	barna	ibolyakék	narancssárga	nem foglalt
(HR)	crno	bijelo	sivo	zeleno	crveno	plavo	zuto	smeđe	ljubičasto	narandasto	nije zauzeto
(BUL)	черен	бял	сив	зелен	червен	син	жълт	кафяв	виолетов	оранжев	свободно
(RO)	negru	alb	gri	verde	roșu	albastru	galben	maro	violet	portocaliu	liber
(RU)	черный	белый	серый	зеленый	красный	голубой	жёлтый	коричневый	пурпурный	оранжевый	свободно
(LT)	juoda	balta	pilka	žalia	raudona	mėlyna	geltona	ruda	purpurinė	oranžinė	laisva
(LV)	melna	balta	pelēka	zaļa	sarkana	zila	dzeltēna	brūna	purpur-sarkana	oranža	brīvs
(EST)	must	valge	hall	roheline	punane	sinine	kollane	pruun	purpur-punane	oraanz	vaba
(SLO)	črna	bela	siva	zelena	rdeča	modra	rumena	smeđ	vijoličast	oranžen	ni zasedeno
(SK)	čierny	biely	šedý	zelený	červený	modrý	žltý	hnedý	fialový	pomaraňový	neobsadený

43

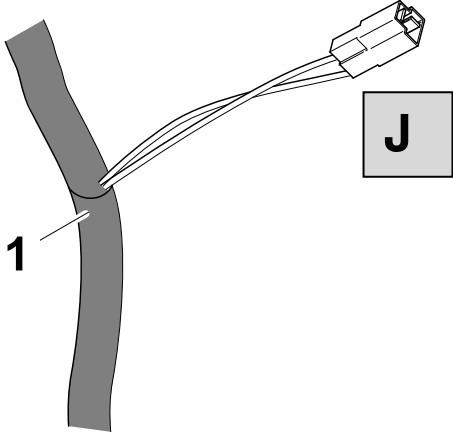
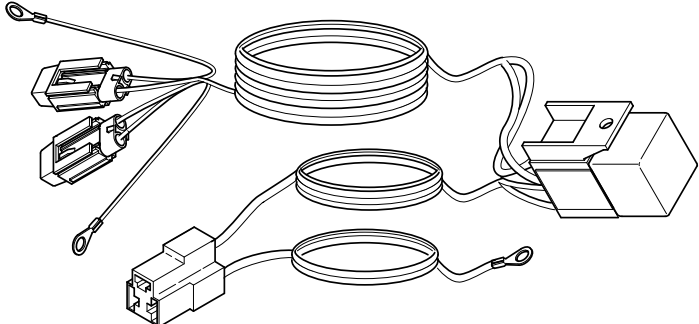
		JAEGER Artikelnummer: JAEGER part number:	<b>22400150</b>
			

44

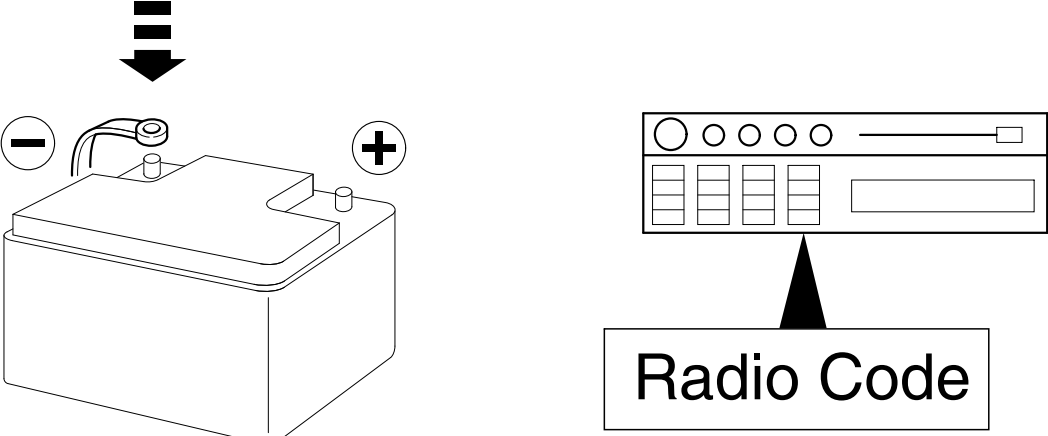

Radio Code

45 CHECK

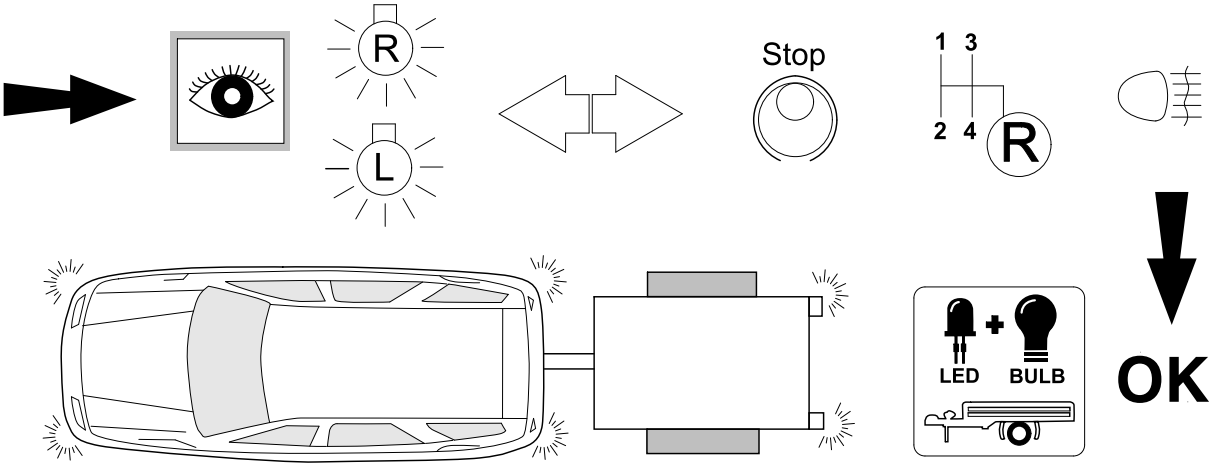

OK



**47 CHECK**

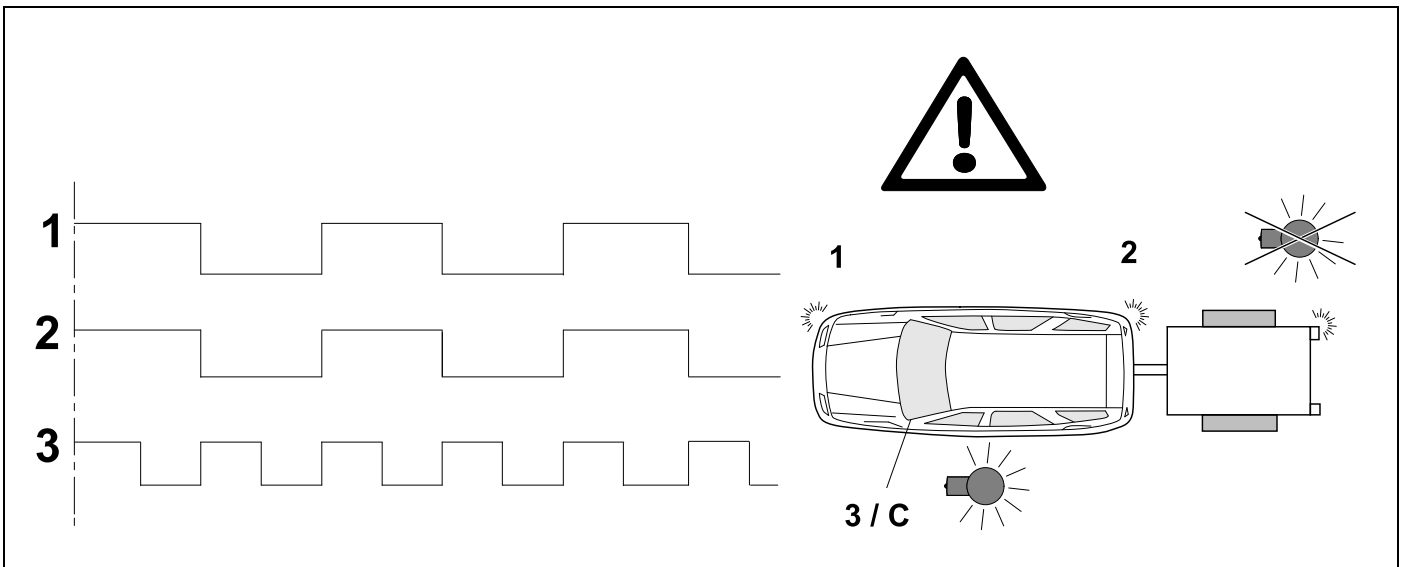



## Anhängerbetrieb konfigurieren / Set up trailer operation

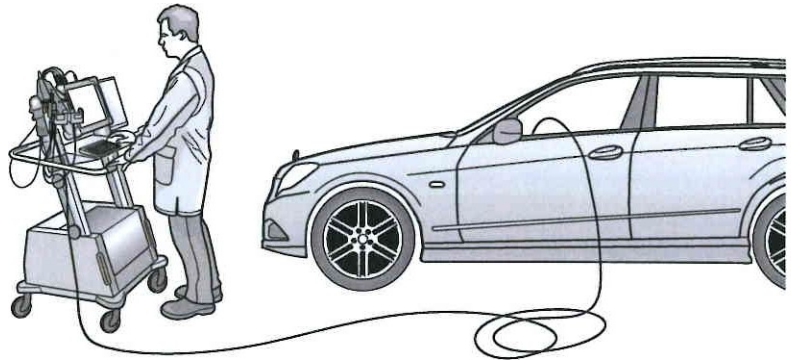

**D**

Die Aktivierung der Anhängerfunktionen muss wie folgt durchgeführt werden:

1. Computer mit Auto verbinden
2. Programm starten
3. Klicke auf „sonderfunktionen“
4. Klicke auf  
"Eingabe bei Nachrüstungen oder Umbauten"
5. Gebe Benutzernamen und Passwort ein
6. Schreibe 550 beim oberen (+) Feld ein
7. Akzeptiere und beende das Programm.
8. Starte Programm erneut
9. Klicke auf „Steuergeräte Ansicht“
10. Klicke auf „ZGW“ (Zentrales Gateway)
11. Klicke auf „Anpassung“
12. Auf der linken Seite: Klicke auf Konfiguration SCN-Codierung
13. Gehe online und warte ein paar Sekunden
14. In der angezeigten Liste gibt es in der Mitte einen Eintrag mit 550 (mit einem + nebenan).
15. Akzeptieren
16. Fertig

**GB**

The activation of the trailer functions has to be carried as follows:

1. Connect computer to car
2. Start program
3. Click 'Special functions'
4. Click 'Input for retrofits or conversions'
5. Enter your user name and password
6. Write 550 in the upper (+) field
7. Accept and close the program.
8. Start the program again
9. Click 'Controllers View'
10. Click 'CGW' (Central Gateway)
11. Click 'Adjust'
12. On the left side: click Configuration SCN encoding
13. Go online and wait a few seconds
14. In the middle of the list shown there is an entry 550 (with a + alongside).
15. Accept
16. Done

**F**

L'activation des fonctions de la remorque doit être effectuée comme suit:

1. Relier l'ordinateur à la voiture
2. Démarrer le programme
3. Cliquez sur «Fonctions spéciales»
4. Cliquez sur  
«Saisie pour rééquipement ou transformation»
5. Saisissez le nom d'utilisateur et le mot de passe
6. Inscrivez 550 dans la zone(+) en haut
7. Acceptez et quittez le programme
8. Redémarrez le programme
9. Cliquez sur «Vue appareils de commande»
10. Cliquez sur «GWC» (Gateway central)
11. Cliquez sur «Adaptation»
12. Sur le côté gauche:  
Cliquez sur Configuration SCN Codage
13. Rendez-vous en ligne et attendez quelques secondes
14. Vous voyez dans la liste affichée, au milieu, une mention avec 550 (avec un + à côté).
15. Acceptez
16. Terminé

**I**

L'attivazione dell'ormichio funzioni si deve eseguire come segue:

1. Collegare il computer con l'auto
2. Avviare il programma
3. Cliccare su „Funzioni speciali“
4. Cliccare su „Immissione In caso di optional supplementari o modifiche“
5. Digitare il nome utente e la password
6. Digitare 550 nel campo superiore (+)
7. Accettare e chiudere il programma.
8. Riavviare il programma
9. Cliccare su „Vista Comando centralina“
10. Cliccare GWC" (Gateway Centrale)
11. Cliccare su „Adattamento“
12. Sul lato sinistro: cliccare su Configurazione SCN Codifica
13. Collegarsi online e aspettare alcuni secondi
14. Al centro dell'elenco visualizzato c'è la voce 550 (con il segno + a fianco).
15. Accettare
16. Finito

**E**

La activación de las funciones de remolque deberá llevarse a cabo de la siguiente manera:

1. Conectar el ordenador con el coche
2. Iniciar el programa
3. Hacer clic en 'Funciones especiales'
4. Hacer clic en 'Entradas en caso de reequipamientos o modificaciones'
5. Introducir el nombre de usuario y la contraseña
6. Introducir 550 en la casilla superior (+)
7. Aceptar la entrada y finalizar el programa.
8. Volver a iniciar el programa
9. Hacer clic en 'Ver reguladores'
10. Hacer clic en 'GWC' (Gateway central)
11. Hacer clic en 'Adaptación'
12. En el lado izquierdo: Hacer clic en Configuración SCNCodificación
13. Conectarse en línea y esperar un par de segundos
14. En la lista visualizada se encuentra una entrada con 550 en el centro (con un + al lado).
15. Aceptar
16. Listo

**NL**

De activering van de trailer-functies moet als volgt worden uitgevoerd:

1. Computer met auto verbinden
2. Programma starten
3. Klik op „Speciale functies“
4. Klik op "Invoer bij achteraf toegevoegde onderdelen of modificaties"
5. Voer gebruikersnaam en wachtwoord in
6. Schrijf 550 in het bovenste (+) veld
7. Accepteer en beëindig het programma.
8. Start programma opnieuw
9. Klik op „Bekijk besturingsapparaten“
10. Klik op „CGW“ (Centrale Gateway)
11. Klik op „Anpassing“
12. Aan de linkerkant: klik op Configuratie SCN-codering
13. Ga online en wacht een paar seconden
14. Op de aangegeven lijst staat in het midden een input met 550 (met een + er naast).
15. Accepteren
16. Klaar

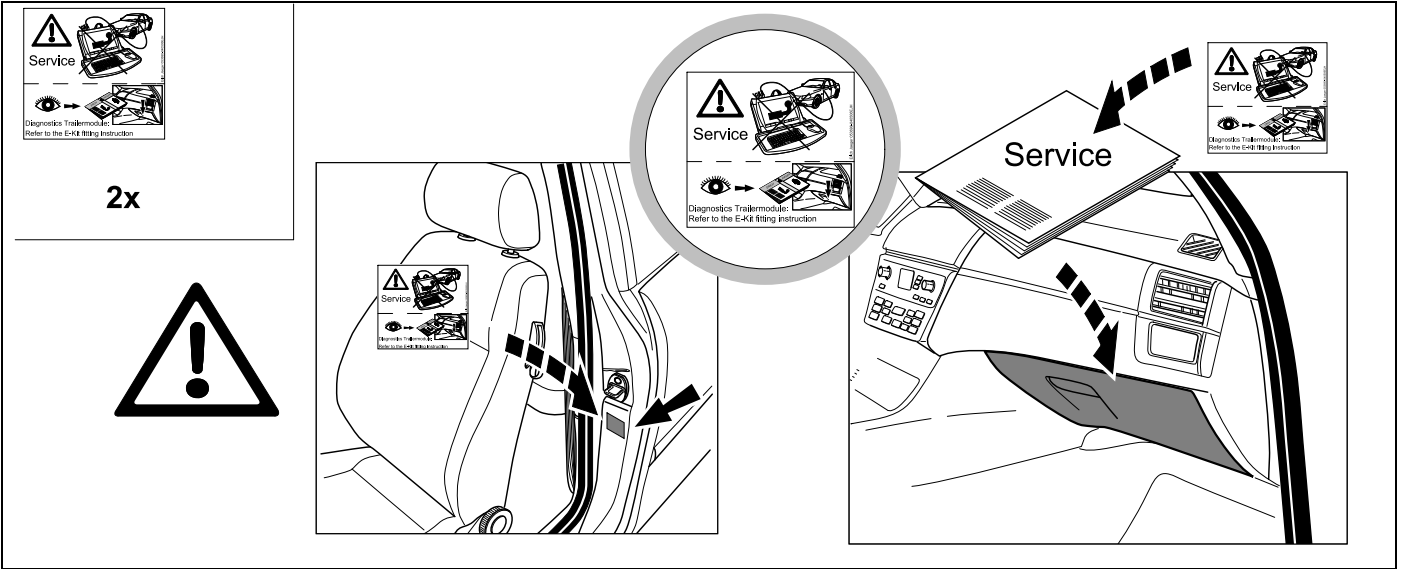



<b>D</b>	Änderungen bezüglich Konstruktion, Ausstattung Farbe sowie Irrtum vorbehalten. Angaben und Abbildungen unverbindlich	<b>PL</b>	Zastrzega się prawo do zmian dot. konstrukcji, wykończenia, kolorystyki oraz pomyłek. Dane i ilustracje niewiążące.
<b>GB</b>	Subject to change in terms of construction, equipment and colour, and may contain errors. The information and illustrations are non-binding.	<b>TR</b>	Tasarım, donanım ve renk bakımından değişiklik yapma hakkı ve hata ve eksiklik mahfuzdur. Veriler ve resimler bağlayıcı değildir.
<b>F</b>	Sous réserve de modifications de la construction, de équipement, de la couleur et sous réserve d'erreurs. Les indications et les illustrations sont sans engagement.	<b>H</b>	A szerkezet, a kivitel és a szín változtatása, valamint a változások joga fenntartva. Az adatok és az ábrák nem kötelező érvényűek.
<b>NL</b>	Wijzigingen met betrekking tot constructie, uitvoering en kleur evenals vergissingen voorbehouden. Gegevens en afbeeldingen niet bindend.	<b>HR</b>	Pravo promjena u svezi konstrukcije, opreme, boje kao i zabune oridžavamo. Podaci i ilustracije su neobavezne.
<b>DK</b>	Ændringer med hensyn til konstruktion, udstyr, farver samt fejl forbeholdes. Oplysninger og illustrationer er uforpligtende.	<b>BUL</b>	Запазени права по отношение на конструкцията, обзавеждането, цвета и грешки. Данните и изобразенията не са обвързващи.
<b>N</b>	Endringer angående konstruksjon, utstyr, farge og feiltagelse forbeholdes. Opplysninger og illustrasjoner uforbindtlig.	<b>RO</b>	Ne rezervăm dreptul unor modificări ale construcției, dotării, culorii și dreptul la erori Datele indicate și imaginile sunt orientative.
<b>S</b>	Med reservation för ändringar vad det gäller konstruktion, utrustning, färg samt för misstag. Uppgifterna och bilderna är inte bindande.	<b>RU</b>	Права на внесение изменений относительно конструкции, оснащения, окраски, а также на ошибки сохраняются. Данные и иллюстрации имеют примерный характер.
<b>FIN</b>	Pidätämme oikeuden rakennetta, varustusta, väriä koskeviin sekä erehdyksestä johtuviin muutoksiin. Tiedot ja kuvat eivät ole sitovia.	<b>LT</b>	Pasilieikama konstrukcijos, įrangos bei reikmenų, spalvos pakeitimų ir klaidų teisė. Duomenys ir iliustracijos neįpareigojantys.
<b>I</b>	Con riserva di modifiche relative a progettazione, dotazione, colore ed errori. Le indicazioni e figure sono fornite senza impegno.	<b>LV</b>	Tiek paturētas tiesības uz konstrukcijas, iekārtu, krāsu izmaiņām, kā arī kļūdīšanās. Dati un attēli bez saistībām.
<b>E</b>	Reservadas las modificaciones respecto a diseño, equipamiento, color, así como error. Indicaciones y figuras sin compromiso.	<b>EST</b>	Konstruksiooni, varustuse ja võevi osas muudatused ning eksimine lubatud. Andmed ja joonised on mittesiduvad.
<b>P</b>	Reservamos o direito de alterações relativamente ao desenho, equipamento, cor, bem como de erro. Os dados e as gravuras não implicam compromisso da nossa parte.	<b>SLO</b>	Zadržana pravica do sprememb glede konstrukcije, opreme, barve ter pomote. Podatki in slike so neobvezne.
<b>GR</b>	Διατηρώνουμε κάθε επιφύλαξη ως προς αλλαγές σε σχέση με κατασκευή, εξοπλισμό, διαρρύθμιση, χρωματισμούς και λάθη παραδρομής.	<b>SK</b>	Zmeny, ktoré sa týkajú konštrukcie, vybavenia, farby, ako aj omyly sú vyhradené. Údaje a zobrazenia sú nezáväzné.
<b>CZ</b>	Změny, týkající se konstrukce, vybavení, barvy, jakož i omyly jsou vyhrazeny. Údaje a vyobrazení jsou nezávazné.		

**JAEGER Artikelnummer**  
**JAEGER part number**

**62930000 OPTIONAL**

